



Custom Enclosure Solutions

Unbeatable Customised and Standardised Enclosure Solutions

Tailored Solutions for Every Need

Whether you're installing electrical equipment in a distributed network or dealing with space constraints, Power On Australia has the perfect enclosure solution for you. Our expertise and experience are at your service, enhancing your business operations with customised design and seamless integration.



Custom Enclosure Solutions

Experience the Power of Our Solutions

Customer-Centered Approach

We collaborate closely with you throughout the entire project to ensure ease of deployment:

- Define full user requirements (function, space, diagnostics, alarms, performance analysis, etc.)
- Ensure full compliance with local and national government standards.
- Innovate for the lowest deployment cost by addressing existing infrastructure challenges.
- Offer any configuration you need—backup power, distribution, genset-ready, remote management, third-party equipment integration, etc.
- Provide factory integration & testing, installation, commissioning, and training.



The CAPEX Advantage

Unbeatable Total Cost of Ownership

- Expert Design: Ensures the lowest deployment cost.
- Optimised Factory Configuration: Protect your assets with durable enclosures, including:
- Marine Grade Aluminum for long life.
- Fully sealed designs (up to IP65) with double or single-skinned construction.
- Seismic and wind ratings.

The OPEX Advantage

Minimise Running Costs

- Low Energy Bills: Comprehensive remote monitoring & control, including demand response.
- Efficient Cooling: Standard and Fresh Air Cooled, High-efficiency heat exchanger technology or Air Conditioned
- Maintenance-Free: No filters and long-life fans.

Custom Enclosure Solutions

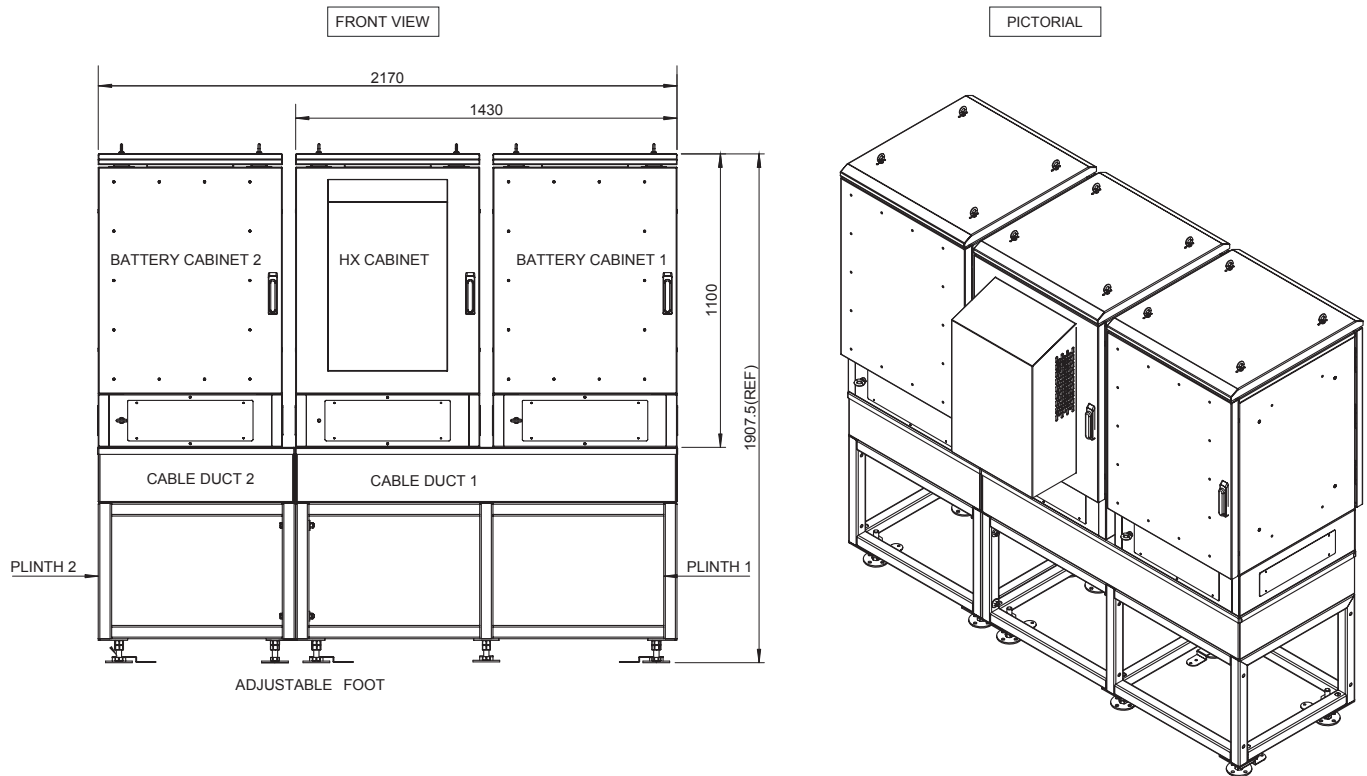

Market Leadership You Can Trust

With extensive experience in collaborative enclosure design and deployment across various industries, including telecommunications, mining, and industrial sectors—Power On Australia stands as a market leader.

Applications Include:

- Telecommunications: Mobile, Broadband
- Control Systems: Wastewater, Power Transmission, Telemetry
- Security: CCTV
- Railway: Signaling & Communications
- etc

End to End Service Capability

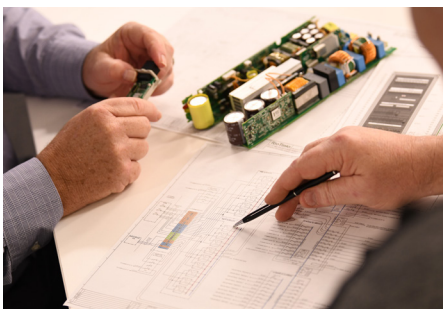

Definition & Design



Integration & Testing



Installation & Commissioning

Custom Enclosure Solutions

Maintenance Free Design

Specialising in accommodating 19" Rackmount Power and Communications equipment for arduous environments and custom telecommunications systems, we pride ourselves in making sure we design cabinets that become relatively maintenance free by considering and including:

- Low Running Costs
- Fully Sealed Design(Dust & Corrosion Free)
- Zero Maintenance (No Filters & Long Life Fans)
- High Cooling Capacity
- etc



About Us

Power On Australia specialises in the design, assembly, installation, and maintenance of power quality and power management solutions including the customised enclosure solutions to house them – all passionately tailor-made to meet our customers' specific needs.

Power On Australia: Empowering your business with unbeatable enclosure solutions. Unbeatable Customised and Standardised Enclosure Solutions.

