

# ABB Power Protection Solutions

## PCS100 AVC-40, 150 kVA to 3600 kVA Active Voltage Conditioner for sag correction

Product Brochure



# PCS100 AVC-40 Active Voltage Conditioner – for sag correction

## 150 kVA to 3600 kVA

Industries in developed countries, with modern power networks, are not immune to voltage problems. Although utilities endeavor to supply reliable, high-quality power, voltage sags and surges will continue to be a fact of life.

The PCS100 AVC-40 is an active voltage conditioner designed to solve these problems. It is a high performance power electronic system, designed for industrial and large commercial applications. It responds instantly to power quality events, providing continuous regulation of voltage.

### Key benefits

#### + Continuous protection from the most common utility voltage problems found in modern power networks

Even the most modern power networks are not perfect and voltage sags are the most common cause of equipment malfunction in today's automated industry. The PCS100 AVC-40, built on a proven and dependable converter platform, provides instant voltage sag and surge correction, ensuring maximum productivity.

#### + Failsafe worry free operation even in harsh electrical environments

The PCS100 AVC-40 is specifically designed for industrial and large commercial applications. Its industrial design and rugged overload capability means it can handle conditions that others cannot. Furthermore, it contains a redundant internal bypass system that ensures that the load continues to be supplied from the utility.

#### + Faster return on investment due to low operation costs

With industry leading efficiency exceeding 98 percent the PCS100 AVC-40 has minimal heat rejection, resulting with minimal costs for electricity and cooling. The PCS100 AVC-40 requires no batteries, as it draws the additional energy required to make up the correction voltage from the utility supply. With no ongoing maintenance costs typically associated with batteries the cost of ownership for a PCS100 AVC-40 systems is very low.

As the system is has a small footprint, it can be easily fitted into equipment rooms or confined spaces, eliminating the need to design and build added floor space.

### Key features

- Proven and dependable converter platform with sophisticated control software
- Industrial design with rugged overload capability
- Modular design providing high reliability and low mean time to repair
- Redundant internal bypass providing fail-safe operation
- No battery energy storage required
- Reduced maintenance and long design lifetime
- Small footprint with industry leading power density
- Connectivity allowing email notification of power quality events
- Multilingual graphical touch screen interface
- Class leading efficiency of more than 98 percent

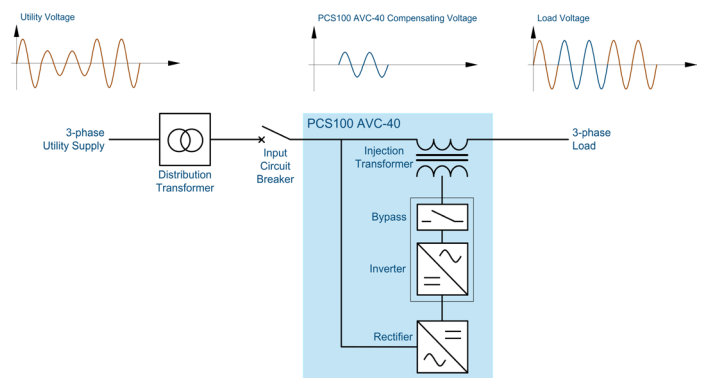

# Complete power protection of commercial and industrial loads

## Typical applications



### Electronics industry

Sensitive machinery  
Clean room control

### Food and beverage

High speed bottling  
Packaging lines  
Dairy processing

### Continuous process

Fibre production lines  
Film production lines  
Extrusion process



### Automotive

Welding process  
Coating process  
Painting process

### Pharmaceutical

Batch process  
Climate control

### Medical

Sensitive medical  
imaging equipment

## Performance

Utility Supply Problem	Input	Output	Correction Time
Three-phase utility sags correction from	60% remaining supply voltage	100%	30 seconds
	50% remaining supply voltage	90%	10 seconds
	40% remaining supply voltage	70%	600 milliseconds
Single-phase utility sags correction from	45% remaining voltage	100%	30 seconds
	0% remaining voltage	57%	600 milliseconds
Single-phase utility swells correction from	115% voltage	100%	Continuous
Three-phase utility under-voltages to 90% of the nominal supply voltage		100%	Continuous
Three-phase utility over-voltages up to 110% of the nominal supply voltage		100%	Continuous
Correction of phase angle errors created by faults in the supply system		Yes	
Correction of voltage imbalance from utility supply		Yes	
Attenuation of flicker voltages in the utility supply		Yes	

## Technical specifications

Utility – Input		Environmental	
Power Range	150 – 3600 kVA Note: Higher power available on request	Operating temperature range	0° C to 50° C
Voltage (model specific)	220 V – 480 V, 3-phase	Noise	< 75dBA @ 2 m
Nominal supply frequency	50 Hz or 60 Hz	Enclosure rating	IP20
Load – Output		User Interface	
Voltage	To match nominal input voltage	User Interface	8.4" color touch panel, multilingual
Displacement Power Factor	0 lagging to 0.9 leading	Touch panel	Full parameter control, voltage event log
Efficiency	>98%	Communication	Ethernet, Modbus TCP, E-mail
Sag correction response	Initial < 250 µs, complete < ½ cycle	Standards and Certifications	
Voltage regulation accuracy	±1% typical, ±2% maximum	Quality	ISO 9001
Sag correction accuracy	±4%	Environmental	ISO 14001
Continuous regulation range	±10%	Marking	CE, C-Tick
Sag correction capability	40%	Safety	IEC 62103
Overload capability	150% for 30 seconds, once every 500 s	Electromagnetic compatibility	Emissions: CISPR 11 Class A Group 1 Immunity: IEC 61000-6-2
Bypass overload capacity	125% for 10 minutes, 150% for 1 minute, 500% for 1 s, 2000% for 200 ms	Performance	IEC 61000-4-34

For further technical information, please refer to the PCS100 AVC-40 Technical Catalogue.

PCS100 AVC-40 Active Voltage Conditioner | Product brochure 3



1300 662 435  
poweronaustralia.com.au

Power On Australia Pty Ltd - ABN 48 110 752 442

Unit 20, 256-258 Musgrave Road, Coopers Plains QLD 4108 (Head Office)  
Po Box 5322, Daisy Hill QLD 4127