

Access Power Solutions Installation and Operation Guide (APS3-300 Series)

Issue: IPN 997-00012-48C

Issue Date: November 2009

Refer to the separate SC200 or SC100 system controller handbook for full details of the system controller operation - www.powerquality.eaton.com/DC-Manuals.

**Eaton Corporation
Telecommunications Power Solutions
www.eaton.com/telecompower
DCinfo@eaton.com**

Eaton Corporation disclaims any liability for direct, indirect, incidental, special or consequential damages arising out of the application or use of any information contained in this document. The foregoing disclaimer applies to damages or personal injury, property damage, loss of operation, loss of profits, loss of product or loss of time, whether incurred by the purchaser, the purchaser's employees or third party.

Information in this document does not constitute a warranty, representation or guarantee concerning the suitability or performance of Eaton products. No such warranty, representation or guarantee is expressed or implied.

Information contained in this document is subject to change without further notice.

Subject to the right to use its equipment, Eaton Corporation does not convey any right, title or interest in its intellectual property, including, without limitation, its patents, copyrights and know-how.

No part of this document may be reproduced or transmitted in any form, by any means or for any purpose other than the Purchaser's personal use, without the express written permission of Eaton Corporation.

Eaton[®], Powerware[®], Intergy[™], CellSure[™], SiteSure[™], PowerManagerII[™] and DCTools[™] are trade names, trademarks, and/or service marks of Eaton Corporation or its subsidiaries and affiliates. Unless otherwise noted, brands, product names, trademarks or registered trademarks are the property of their respective holders.

Copyright © 2007-2009 Eaton Corporation. All Rights Reserved.

Scope

This guide covers installation, operation and maintenance of Access Power Solutions (APS3-300 Series) dc power systems (APS), controlled by the SC200 or SC100 system controller.

Refer to the separate SC200 or SC100 system controller handbook for full details of the system controller operation - www.powerquality.eaton.com/DC-Manuals.

Audience

This guide is intended for use by:

- Installers competent in:
 - installing and commissioning dc power systems
 - safe working practices for ac and dc powered equipment
 - the relevant local electrical safety regulations and wiring standards
- Operators and maintenance staff competent in:
 - operation of dc power systems
 - safe working practices for ac and dc powered equipment

Related Information

- SC100 System Controller Operation Handbook* - IPN 997-00012-63
- SC200 System Controller Operation Handbook* - IPN 997-00012-50
- *PowerManagerII* Online Help
- *DCTools* Online Help
- SiteSure-3G Installation and Operation Guide - IPN 997-00012-51

* Download from: www.powerquality.eaton.com/DC-Manuals
<http://powerquality.eaton.com/DC-Manuals>.

Reporting Problems with this Guide

Please use this email address to report any problems you find in this guide:

Eaton DC Product Marketing Communications
EMAIL: DCMarketingNZ@eaton.com

For Further Information and Technical Assistance

For further information and technical assistance see Worldwide Support on page [103](#).

About This Guide

Scope.....	i
Audience.....	i
Related Information.....	i
Reporting Problems with this Guide.....	i
For Further Information and Technical Assistance.....	i

Chapter 1

General Description

Overview.....	1
Access Power Solutions DC Power Systems.....	2
Front View.....	2
Rear View.....	3
Rectifiers.....	4
System Controller.....	5
SC200 System Controller.....	5
SC100 System Controller.....	5
Compatible Software.....	6
Input/Output Board.....	6
Connections.....	8
Other Features.....	9
External communications.....	9
Low Voltage Disconnect Option.....	9
Battery Mid-point Monitoring Option (SC200 only).....	10

Chapter 2

Preparation

Overview.....	11
Warnings.....	12
Inspecting the Equipment and Reporting Damage.....	14

Chapter 3

Installation

Overview.....	15
Installation Tasks.....	16
Task 1 - Check the AC Supply and Earthing.....	16
Task 2 - Prepare APS.....	19
Task 3 - Connect the AC Supply Cable.....	22
Task 4 - Mount the APS in the Rack.....	25
Task 5 - Connect the DC Load and Battery Cables.....	26
Task 6 - Install the Batteries.....	27
Task 7 - Mount the Battery Temperature Sensor.....	28
Task 8 - Connect External Input/Output Cabling (if required).....	29
Task 9 - Connect Additional Input/Output (if required - SC200 only).....	31
Task 10 - Connect to the AC Supply Point.....	31
Installation Completed.....	32

Chapter 4

Start-Up

Overview.....	33
Start-Up Tasks.....	34
Task 1 - Inserting the Rectifiers.....	34
Task 2 - Pre-Power-Up Checklist.....	35
Task 3 - Applying AC Power.....	35
Task 4 - Configuring the DC Power System.....	36
Task 5 - Applying DC Power to Battery and Load.....	37
Start-Up Completed.....	38

Chapter 5	System Controller	
	Configuration File.....	40
	Backup and Restore	40
	Starting the SC200 or SC100	41
	SC200	41
	SC100	42
	SC200 or SC100 Operation using the Keypad and Screen	42
	Keypad Access Security	42
	Alarm Indicators	43
	SC200 or SC100 Operation Using a PC/Laptop	44
	Using DCTools via USB (SC200 only)	44
	Using DCTools via RS232	45
	SC200 or SC100 Identity Information	46
Chapter 6	Maintenance	
	Overview.....	49
	Troubleshooting.....	50
	System Problems	50
	System Controller Problems.....	53
	Replacing or Adding a Rectifier	58
	Replacing or Adding a Load MCB	59
	Replacing the System Controller	60
	Replacing the Input/Output Board	63
	Battery Mid-point Monitoring (String Fail) Alarm (SC200 only).....	65
	Battery Disposal and Recycling	65
Appendix A	Equipment and Tools	
	Safety Equipment.....	67
	Essential Tools	67
	Recommended Tools	67
	Spare Parts	68
	Standard Torque Settings	68
Appendix B	Specifications	
Appendix C	Controller Menus	
	SC200 Menu.....	75
	SC100 Menu.....	76
Appendix D	Connector Pin-outs	
	System Controller Connector Pin-outs	77
	I/O Board (IOBGP-00, -01) Connector Pin-outs	79
Appendix E	Transient Protection	
Appendix F	Earth Bonding	
Appendix G	Commissioning	
	Analog Inputs.....	90
	System Controls	92
	System Alarms	96
	Digital Inputs.....	99
	Digital Outputs (Relays)	100
	Commissioning Completed.....	100
Equipment Incident Report		
Worldwide Support		
Index		

Overview

Topic	Page
Access Power Solutions DC Power Systems	2
Rectifiers	4
System Controller	5
Input/Output Board	6
Other Features	9

Access Power Solutions DC Power Systems

Front View

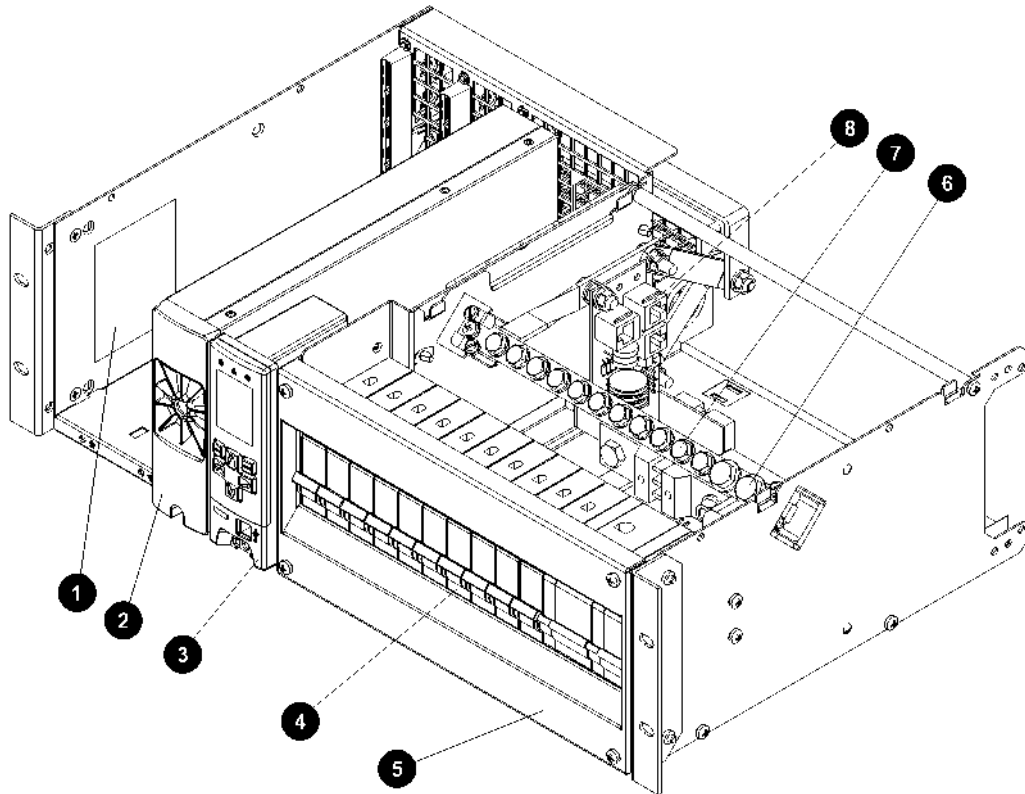

- ❶ AC Rating Label
 - ❷ Rectifier modules (see details on page 4)
 - ❸ SC200 or SC100 system controller (see details on page 5)
 - ❹ Integrated dc distribution with up to 10 Load and 2 Battery Miniature Circuit Breakers (MCBs)
 - ❺ DC distribution cover
 - ❻ DC common bus battery terminals
 - ❼ DC common bus load terminals
 - ❽ Voltage Feed Module with connector for optional SiteSure-3G I/O module
- ☐ *Optional top cover not shown (IPN: 621-08919-30).*

Rear View

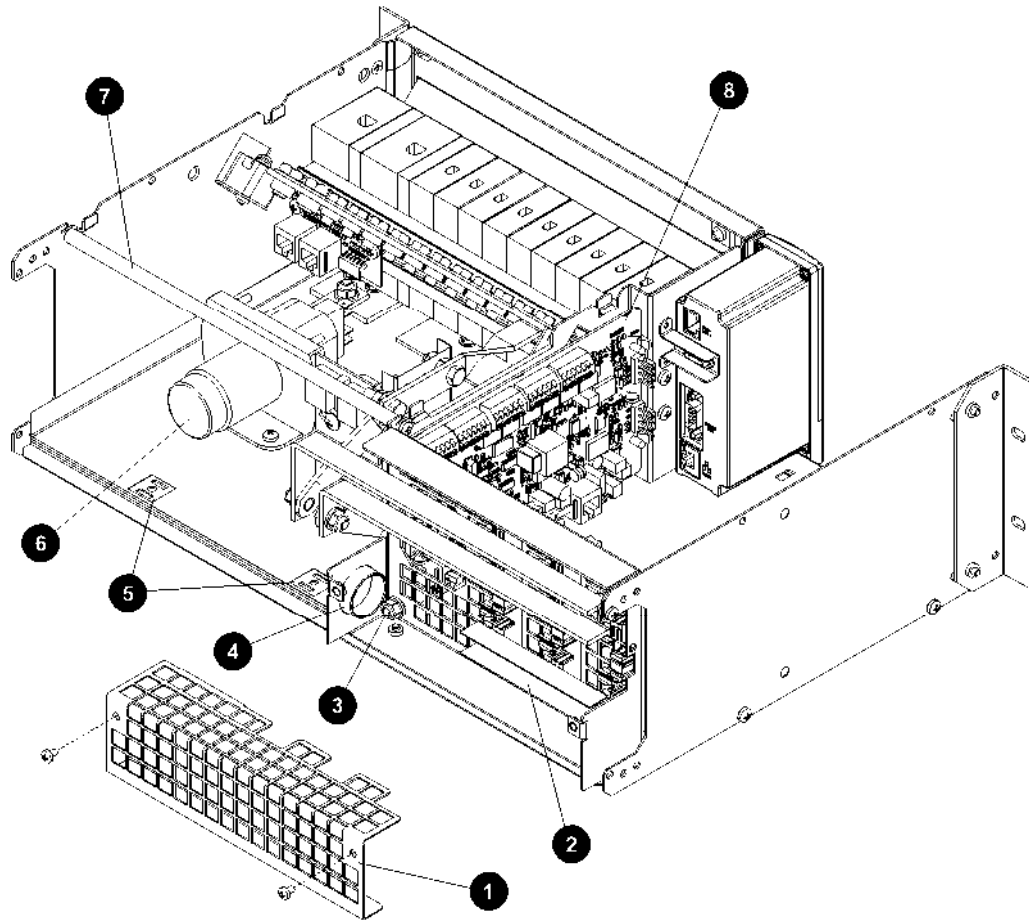

- | | |
|--|--|
| ① AC terminal cover | ⑤ Cable tie points |
| ② AC phase/neutral terminals (see connection details on page 22) | ⑥ Optional Low Voltage Disconnect (LVD) (see details on page 9) |
| ③ AC earth conductor connection point (see connection details on page 22) | ⑦ Load and battery cable tie rod |
| ④ AC cable entry gland | ⑧ I/O Board (see details on page 6) |

 AC supply cord(s) may be pre-fitted.

Rectifiers

Access Power Solutions are fitted with either 48V, 2000W (APR48-ES); 48V, 1800W (APR48-3G); 48V, 900W (EPR48-3G) or 24V, 1440V (APR24-3G) rectifiers. The rectifiers are fan-cooled and hot-pluggable.

☐ See Specifications on page 71 for further information. See Troubleshooting on page 50 for details of rectifier alarms.

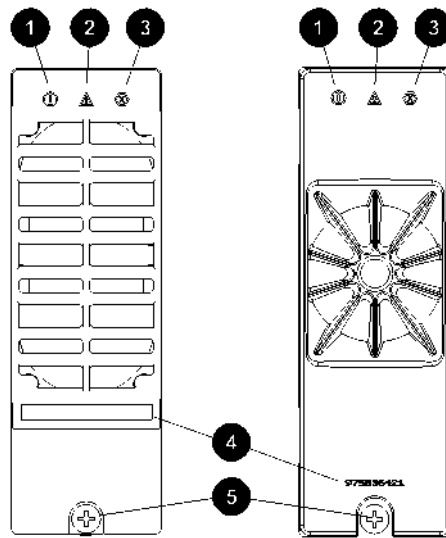

Left: APR24-3G and APR48-3G
Right: APR48-ES

- ① Power On LED (Green)
- ② Minor Alarm LED (Yellow)
- ③ Major Alarm LED (Red)
- ④ Serial Number
- ⑤ Retaining Screw. Tighten to 13.3 inch-pounds (1.5Nm).

System Controller

The SC200 or SC100 system controller provides control, communications and alarm functions.

The system controller is supplied pre-configured. Configuration changes can be made with the keypad, or via a PC connected to the USB connector (SC200) or RS232 (SC100) connector. Or changes can be made remotely (see External Communications on page 9).

Basic operating information is available in System Controller on page 105. For further details refer to the System Controller Operation Handbook (see Related Information on page i).

See Troubleshooting on page 50 for details of system controller alarms.

SC200 System Controller

The SC200 system controller is an advanced control and monitoring solution which provides a full suite of communications options, including built-in Ethernet interface, Web server, and SNMP agent.

Alarm notifications may be by SNMP traps, SMS text messaging, dial-out to PowerManagerII remote monitoring software, or relay contact closures.

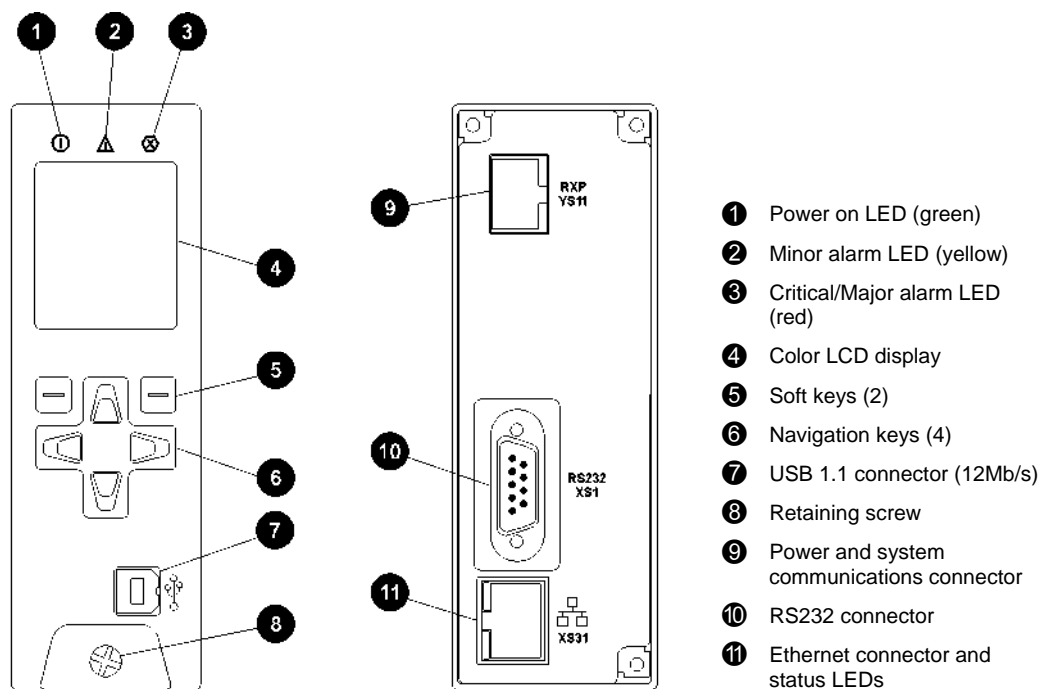

SC100 System Controller

The SC100 system controller is a full-featured control and monitoring solution which provides alarm notifications via dial-out modem to PowerManagerII remote monitoring software, SMS text messaging, or by relay contact closures.

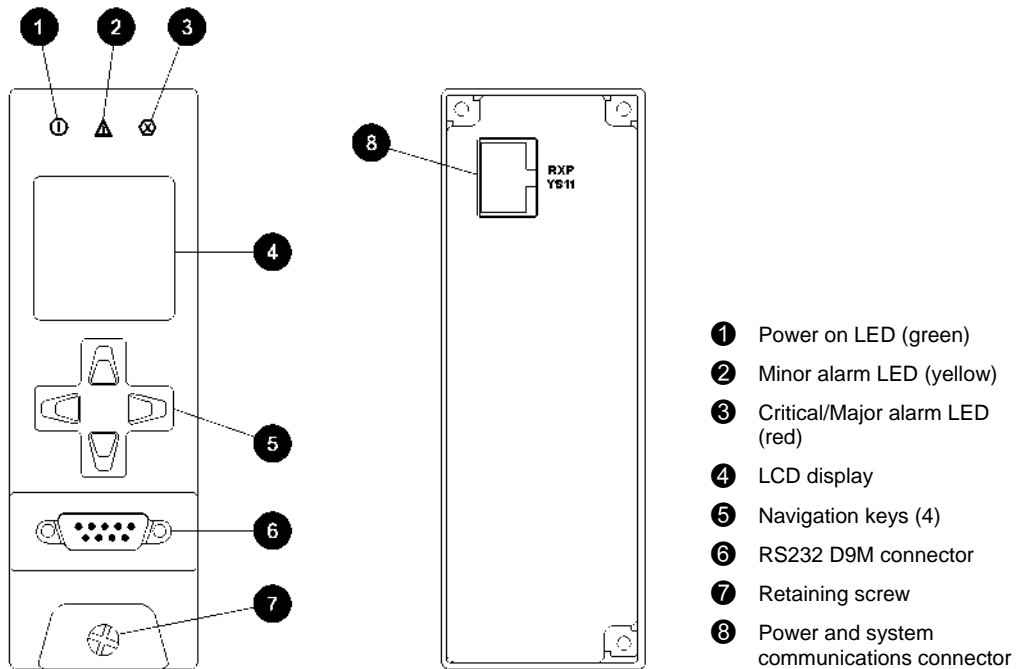

- ❶ Power on LED (green)
- ❷ Minor alarm LED (yellow)
- ❸ Critical/Major alarm LED (red)
- ❹ LCD display
- ❺ Navigation keys (4)
- ❻ RS232 D9M connector
- ❼ Retaining screw
- ❽ Power and system communications connector

Compatible Software

The following software is compatible with the SC200 or SC100 system controller:

- DCTools Configuration Software. Latest version is available free from www.powerquality.eaton.com/downloads.
- PowerManagerII Remote Control and Monitoring Software. Contact your Eaton dc product supplier for further information (see Worldwide Support on page [103](#)).
- Recommended web browsers (SC200 only): Microsoft Internet Explorer 8 (IE6 is compatible but with reduced performance), Mozilla Firefox 3.0.

Input/Output Board

The input/output (I/O) board provides the I/O interfaces and connections for the SC200 or SC100 system controller.

The I/O board includes a range of sense inputs for dc power system control and monitoring. It also allows real time data collection from building services and other external devices, and relay outputs for alarm signals or control of external devices.

The I/O functions are:

Sensors: Current - 3, Bus voltage - 1, Temperature - 2, Battery Mid-point - 4 (SC200 only)

Input/Output: Digital inputs: 4 pre-defined system functions, 6 user-defined
Relay outputs: 6 (one also used as Monitor OK alarm)
LVD contactor outputs: 2

 For input and output specifications see details on page [72](#). For connector pin-outs see details on page [79](#).

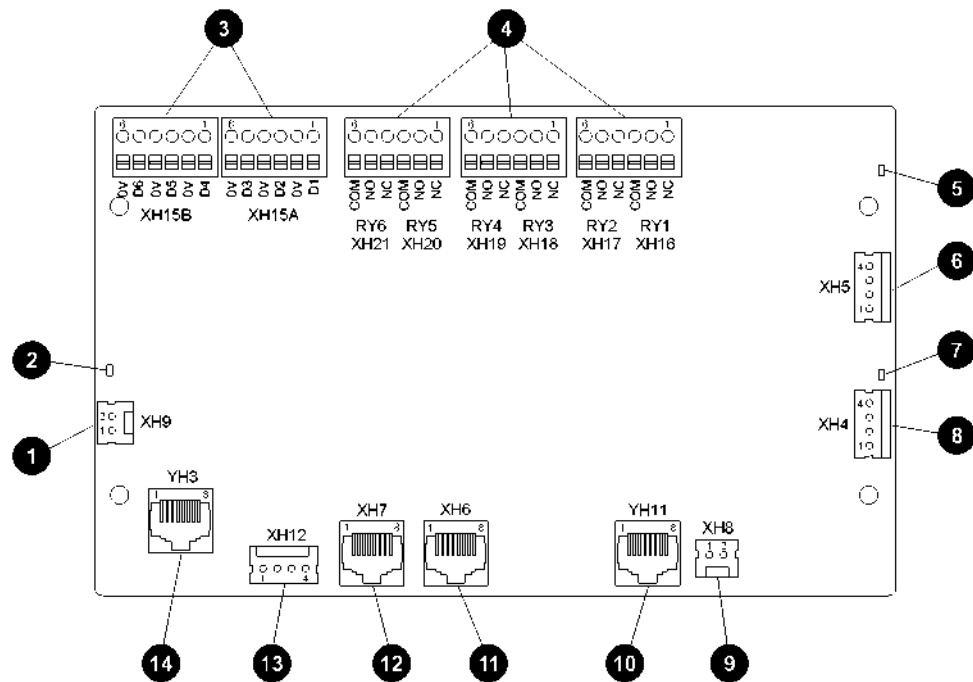

- | | |
|---|--|
| <ul style="list-style-type: none"> ❶ Bus voltage sense input - XH9 ❷ Power/Comms OK LED (green) ❸ Digital inputs D1-D6 (6 user defined) - XH15A, XH15B ❹ Digital (relay) outputs RY1-RY6 (6) - XH16-XH21 ❺ LVD contactor 2 status LED (green) ❻ LVD contactor 2 connector - XH5 ❼ LVD contactor 1 status LED (green) | <ul style="list-style-type: none"> ❽ LVD contactor 1 connector - XH4 ❾ LVD power input connector - XH8 ❿ Power and RXP comms input - YH11 ⓫ Current sense inputs (3) - XH6 ⓬ Temperature sense inputs (2) - XH7 ⓭ Battery Mid-point Monitoring sense inputs (SC200 only) - XH12 ⓮ DC power system digital inputs (4 pre-defined: Load Fuse Fail, Battery Fuse Fail, AC Distribution Fan Fail, AC Distribution MOV Fail) - YH3 |
|---|--|

☐ See Troubleshooting on page 50 for details of I/O board LED signals.

Connections

The following diagram shows the connections between the SC200 or SC100, the I/O board, the other dc power system components and external devices.

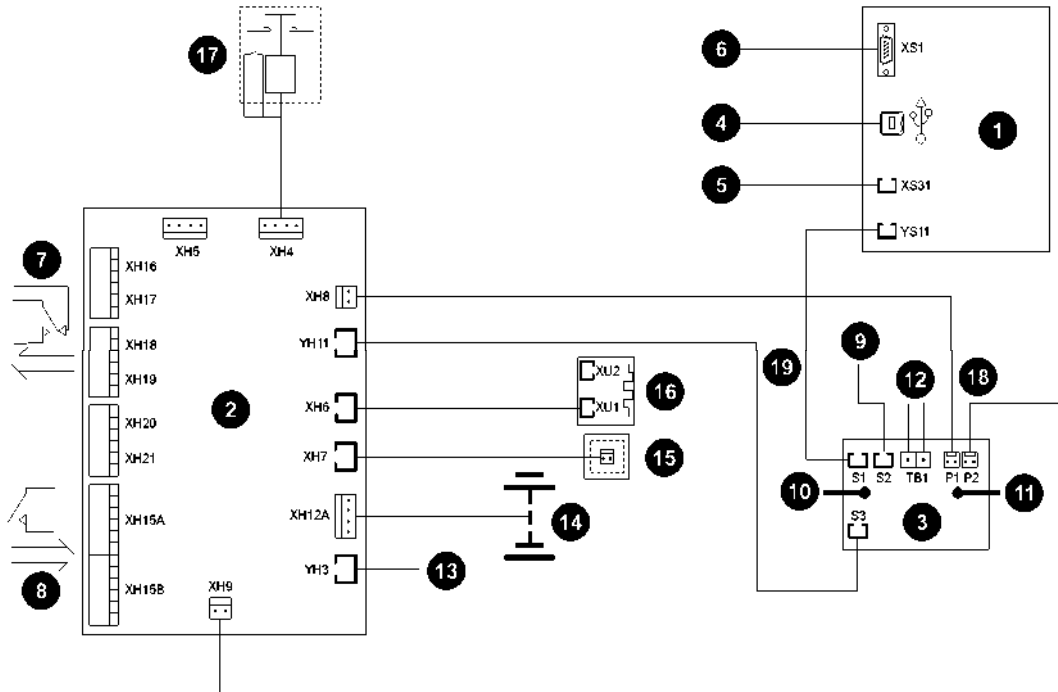

- | | |
|---|---|
| <ul style="list-style-type: none"> ① SC200 or SC100 system controller ② I/O board ③ Voltage feed module ④ USB communications (SC200 only) ⑤ Ethernet communications (SC200 only) ⑥ RS232 communications ⑦ Digital relay outputs (6) to external devices and/or alarm indication system ⑧ Digital inputs (6) from external voltage-free switches or relay contacts ⑨ Connection to additional I/O board(s) and/or SiteSure-3G I/O module(s) (SC200 only) ⑩ Connection to dc common bus | <ul style="list-style-type: none"> ⑪ Connection to dc live bus ⑫ Communications to rectifiers ⑬ DC power system digital inputs (Load Fuse Fail, Battery Fuse Fail, AC Distribution Fan Fail, AC Distribution MOV Fail) ⑭ Connections to battery mid-points (4) (SC200 only) ⑮ Connection to temperature sensors (2) ⑯ Connection to current sensors (3) ⑰ Optional LVD contactor and auxiliary switch ⑱ Bus voltage sense and LVD power connections ⑲ I/O and system controller power and RXP comms connection |
|---|---|

 For connector pin-outs see details on page [79](#). For input and output specifications see details on page [71](#).

Other Features

External communications

Refer to the system controller handbook for information on these communications options.

Communications options	SC200	SC100
Communication with <i>DCTools</i> via USB	✓	-
Communication with <i>DCTools</i> or <i>PowerManagerII</i> via RS232	✓	✓
Communication with <i>DCTools</i> or <i>PowerManagerII</i> via an external PSTN or GSM modem (dial-in and dial-out on alarm)	✓	✓
Communication with <i>DCTools</i> or <i>PowerManagerII</i> via Ethernet	✓	-
Communication with web browser software via an IP network	✓	-
Communication with a Network Management System (NMS) using SNMP	✓	-
Communication with a Building Management System (BMS) using Modbus	✓	-
Alarm and status messages to GSM Short Messaging Service (SMS) text capable cell phones	✓	✓
Communication with an alarm management system using voltage-free relay contacts (on an IOBGP I/O board)	✓	✓

Low Voltage Disconnect Option

An optional Low Voltage Disconnect (LVD) is available for the Access Power Solutions (APS3-300 Series). See the diagram on page [3](#) for location. This is connected as a battery disconnect.

For information on operation see Low Voltage Disconnect (LVD) in the System Controller Operation Handbook.

Battery Mid-point Monitoring Option (SC200 only)

Battery Mid-point Monitoring provides a cost-effective method for the early detection of internal battery faults. The voltages of the two halves of a battery string are measured and the system controller generates an alarm signal if a voltage imbalance is detected.

A voltage imbalance is an indication that one or more cells has an internal fault. Further investigation can then isolate the faulty cell(s) and action can be taken to correct the problem and prevent a total battery failure.

To connect the Battery Mid-point Monitoring option see details on page [27](#). If a *String Fail* alarm is generated see Troubleshooting on page [50](#).

To ensure reliable operation Mid-point Monitoring operates only when the battery is in float charge and after a configurable lockout period since the last battery discharge, Fast Charge, Equalize or Battery Test.

Overview

Topic	Page
Warnings	12
Inspecting the Equipment and Reporting Damage	14

Warnings

This section contains important warnings. Read these warnings before installing or operating an Eaton Access Power Solutions dc power system.



Electrical Safety

- Access Power Solutions (APS3-300 Series) dc power systems must be mounted in an enclosed cabinet that meets safety and fire enclosure requirements as specified in AS/NZS 60950.1 and EN 60950-1.
- The dc power system may be powered from multiple ac sources. All ac sources must be isolated before internally servicing the equipment.
- The dc power system MCBs are not a disconnect device. The APS dc power system must be connected to a suitable upstream ac supply disconnect device such as Miniature Circuit Breaker(s) (MCB) or fuses. This device must isolate both the phase and neutral conductors in single-phase and three-phase connections, unless the neutral conductor is clearly identified.
- If the dc power system is to be installed in a location where the ambient temperature may rise above 50°C (122°F), then V90 rated cable must be used for all connections.
- The dc power system is not compatible with IT (Impedance Terra) ac power distribution topologies. For advice see Worldwide Support on page [103](#).
- A registered electrician (or suitably qualified person) must check the integrity of the installed cabling, BEFORE the dc power system is powered up.
- Tasks must be performed in the sequence documented in this guide.



Location and Environment

- An APS dc power system must be installed in a restricted access location.
- For ease of access and to maintain optimum system cooling observe the clearances stated on page [25](#).
- Dust build-up within the dc power system may cause premature failure. In dusty environments filter the ventilation air entering the equipment room. Ensure regular cleaning of the air filters.
- Do not allow water or any foreign object to enter the dc power system. Do not place objects containing liquid on top of or near the unit.
- Flooded cell and VRLA lead acid batteries can emit explosive gases and must be installed with adequate ventilation. Refer to the battery manufacturer or supplier for advice on minimum ventilation levels.



Reverse Polarity

- Always check that the battery cables have been terminated to the correct system polarity BEFORE connecting the batteries or closing the battery disconnect device. Connecting batteries to the dc power system with incorrect system polarity will damage the rectifiers and void all warranty claims.



Hazardous Energy Levels

- Rectifiers and batteries contain hazardous energy levels. Only personnel trained and experienced in dc power systems are to service/maintain this equipment.
- Always use insulated tools.
- Do not short-circuit the live and common bus bars or cables.



Batteries

- The plastic cases of batteries installed in Eaton dc power system racks must have a flammability rating of UL 94-V2 or better.
- Flooded cell and VRLA lead acid batteries can emit explosive gases and must be installed with adequate ventilation. Refer to the battery manufacturer or supplier for advice on minimum ventilation levels.
- Do not wear a synthetic dust-coat or overalls. Synthetic fabrics can hold static electric charges that create sparks during discharge.
- Remove rings, wristwatch and other metal jewelry that might be exposed to battery terminals, before installing batteries.
- Batteries are powerful sources of energy and present a potential electrical shock and energy hazard. The energy hazard is always present, even if the batteries are not connected. Avoid short circuiting terminals of opposite polarity.
- Always use insulated tools.
- Do not place tools, loose cables or metal objects (such as interconnecting bars) on top of batteries.
- Do not drop tools, loose cables or metal objects onto intercell connections or terminals of opposite polarity.
- Only terminate cables and interconnecting bars after confirming that the termination will not create a short circuit.
- Always tighten battery terminal bolts according to the battery manufacturer's specification. Failing to do so can cause erratic battery performance, possible damage to the battery, and/or personal injury.
- There is a risk of electric shock if a battery is replaced by an incorrect type.
- Dispose of batteries according to the instructions on page [65](#).



Rectifiers

- Only operate the rectifiers when the surrounding area is clean and dust free.
- To reduce the risk of electric shock and maintain optimum system cooling, always cover empty rectifier slots with blanking panels.
- To avoid electrical shock, do not place hands inside the rectifier magazine.
- Rectifier cases may exceed 100°C (212°F), especially after prolonged operation. Use suitable gloves when removing a rectifier from the magazine.
- Do not attempt to disassemble faulty rectifiers. Return them (in their original packaging) with a completed Equipment Incident Report on page [101](#).
- Ensure that any upstream Residual Current Devices (RCDs) are appropriately rated for the rectifiers' maximum earth leakage current (see Specifications on page [71](#) for value).



DC Distribution(s)

- The dc common bus of the dc power system can be connected to earth (ground). If this connection is made all of the following conditions must be met:
 - Your equipment and the dc power system must be located within the same premises.
 - No switching or disconnecting devices are allowed in the conductor between the dc common line and the point of connection to the earth electrode conductor.
See Connecting the Output to Earth on page [19](#) for further information.
- For installations in the United States, Listed compression connectors must be used to terminate Listed field-wired conductors where required. For all installations, use the appropriate connector for the conductor size as specified by the connector manufacturer. And use only the connector manufacturer's recommended tooling or tooling approved for that connector.
- Follow all applicable local and national rules and regulations when making field connections.
- Tighten all electrical connections to the torques stated in this guide or on the manufacturer's label.



Servicing and Maintenance

- The APS contains hazardous voltages and hazardous energy levels. Before undertaking any maintenance task refer to the Warnings on page [12](#).
- If a maintenance task must be performed on a "live" system then take all necessary precautions to avoid short-circuits or disconnection of the load equipment, and follow any "live-working" instructions applicable to the site.
- Only perform the maintenance tasks described in the Maintenance chapter. All other tasks are classified as Servicing. Servicing must only be performed according to specific instructions and only by personnel authorized by Eaton. This includes disassembly and/or servicing of any modules.
- For further information on Servicing contact your local Eaton dc product supplier, or refer to the contact details on page [103](#).



EMC Compliance

- This dc power system may be used in close proximity to other electronic equipment, provided installation is carried out according to instructions in this guide. However, proper installation and compliance with EMC standards does not guarantee that the dc power system will not respond to electromagnetic disturbances, or will not cause interference to other equipment in a particular installation.
- In a domestic environment this product may cause radio interference in which case the user may be required to take adequate measures.
- This equipment generates, uses, and can radiate radio frequency energy and, if not installed and used in accordance with the instructions, may cause harmful interference to radio communications. However, there is no guarantee that the interference will not occur in a particular installation. If this equipment does cause harmful interference to radio or television reception, which can be determined by turning the equipment off and on, the user is encouraged to try to correct the interference by one or more of the following measures:
 - Reorient or relocate the receiving antenna.
 - Increase the separation between the equipment and receiver.
 - Connect the equipment into an outlet on a circuit different from that to which the receiver is connected.
 - Consult the dealer or an experienced radio/TV technician for help.

Inspecting the Equipment and Reporting Damage

Unpack the equipment and inspect it carefully for possible damage that may have occurred while in transit. Do not use any damaged equipment.

Report any damage immediately, using a completed Equipment Incident Report on page [101](#).



Keep the original packaging to use if any item needs to be returned for replacement or repair.

Overview

Topic	Page
Installation Tasks	<u>16</u>
Task 1 - Check the AC Supply and Earthing	<u>16</u>
Task 2 - Prepare APS	<u>19</u>
Task 3 - Connect the AC Supply Cable	<u>22</u>
Task 4 - Mount the APS in the Rack	<u>25</u>
Task 5 - Connect the DC Load and Battery Cables	<u>26</u>
Task 6 - Install the Batteries	<u>27</u>
Task 7 - Mount the Battery Temperature Sensor	<u>28</u>
Task 8 - Connect External Input/Output Cabling (if required)	<u>29</u>
Task 9 - Connect Additional Input/Output (if required - SC200 only)	<u>31</u>
Task 10 - Connect to the AC Supply Point	<u>31</u>
Installation Completed	<u>32</u>

Installation Tasks

Before starting the installation, review the following information:

- Required Equipment and Tools on page [67](#)
- Warnings and Cautions on page [12](#)
- Inspecting the Equipment and Reporting Damage on page [14](#)

Complete the Installation tasks in the following order:

Task	Description	Reference
1	Check the AC Supply and Earthing	See details on page 16
2	Prepare the APS	See details on page 19
3	Connect the AC Supply Cable	See details on page 22
4	Mount the APS in the Rack	See details on page 25
5	Connect the dc Load and Battery Cables	See details on page 26
6	Install the Batteries	See details on page 27
7	Mount the Battery Temperature Sensor	See details on page 28
8	Connect External Input/Output Cabling (if required)	See details on page 29
9	Connect Additional Input/Output (if required - SC200 only)	See details on page 31
10	Connect to the AC Supply Point	See details on page 31

For installation of external communications see Communications Options.

Task 1 - Check the AC Supply and Earthing

It is important that the ac supply for the Access Power Solutions dc power system includes the correct levels of protection.

Step 1 - Check transient voltage protection at the site



- 1 Confirm that there is a transient protection plan (compliant with IEC 61643-12) for the site.
 For more information see *Transient Protection* on page [83](#).
- 2 If necessary, install suitable transient protection.

Step 2 - Check high ac voltage protection at the site



- 1 Check if the ac voltage is expected to exceed 275V (L-N).
- 2 If so, then it is strongly recommended that an external high voltage protection unit (HVPU) be installed. This will automatically disconnect the ac at high voltage and reconnect it at normal voltage.
- 3 Install the HVPU as in the following diagram.
- 4 Connect the High VAC alarm output to one of the Digital Inputs on the I/O board (see the diagram on page 6 for location).

The High VAC alarm signal lines must be isolated from the ac supply by a voltage-free relay contact.

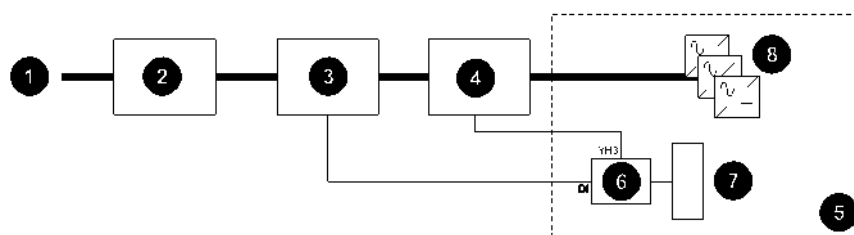

- | | |
|--|------------------------------------|
| ① AC supply | ⑤ dc power system |
| ② Primary transient protection devices | ⑥ I/O board |
| ③ High voltage protection unit with alarm output | ⑦ SC200 or SC100 system controller |
| ④ Secondary transient protection devices (MOVs) | ⑧ Rectifiers |

Step 3 - Check the type of ac supply, disconnect device and RCDs



- 1 Check the type of ac supply. Only the types of ac supply listed in Task 3 on page 22 are suitable for the APS.
 - Only use a two-phase or three-phase (L-L) ac supply if referenced to earth, or a protection system is in place so that the phase-earth voltage cannot exceed the rating of the rectifier.*
- 2 Check that the APS will be connected to a suitable upstream ac disconnect device such as Miniature Circuit Breaker(s) (MCB) or fuses.
- 3 Check the disconnect device will isolate both the phase and neutral conductors in single-phase and three-phase connections, unless the neutral conductor is clearly identified.
- 4 Check that any Residual Current Devices (RCD) upstream of the APS are rated for the maximum earth leakage current of the rectifiers. If necessary, install higher rated RCD(s).

The maximum earth leakage current of Access Power Rectifiers is given in the Specifications on page 71.

Step 4 - Check ac discrimination



Each rectifier has two internal fast-acting fuses. Under certain internal fault conditions these fuses will blow.

If there is insufficient discrimination between these fuses and any upstream ac supply-disconnect device then the upstream ac supply-disconnect device will operate before a rectifier fuse blows. This will disconnect the ac supply to all rectifiers.

- 1 Check the time-current (tripping) curve(s) of all ac supply-disconnect device(s) upstream of the APS with the following curve for the rectifier fuses.

Refer to the manufacturer's data for tripping curves.

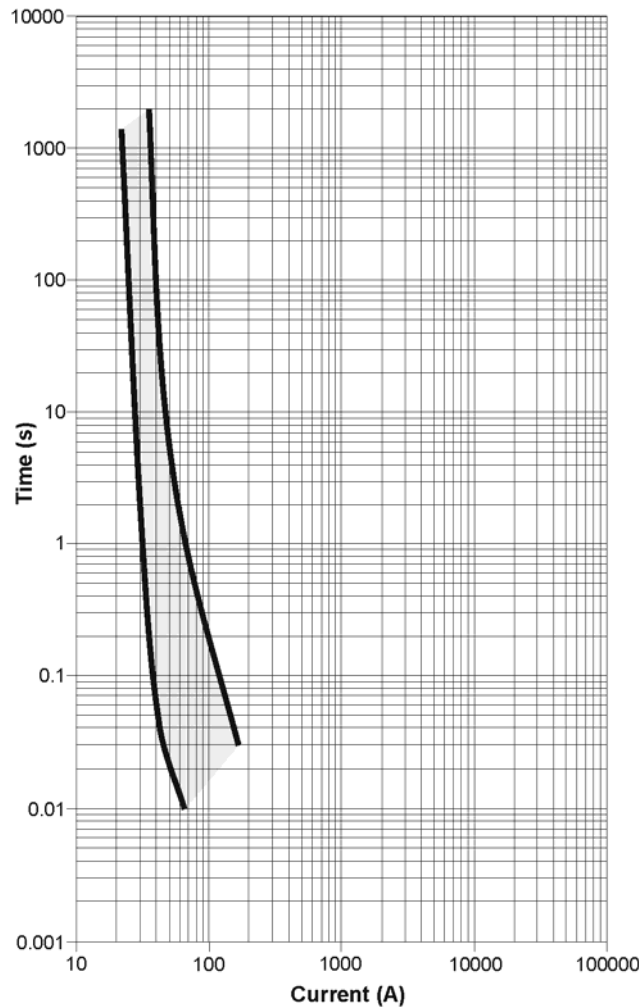

Time-Current Curve (minimum and maximum) for APR-3G internal fuses (IEC 60127-2).

Source: Schurter SP 5x20 Pigtail data sheet.

- 2 No action is required if the time-current curves of the upstream ac supply-disconnect devices are entirely to the right of the curves for the rectifier fuses.

- 3 If the curve of an upstream ac supply-disconnect device crosses the curve for the rectifier fuse there may not be adequate discrimination.

If necessary, replace the upstream ac supply-disconnect device to achieve adequate discrimination. Or, contact your Eaton dc product supplier for advice (see Worldwide Support on page [103](#)).

Step 5 - Check the earthing arrangements at the site

Confirm that all earths are brought together at one "star" point so that surge currents cannot flow in "earth loops" and create large voltages.

For more information see *Transient Protection* on page [83](#).

Procedure complete**Task 2 - Prepare APS****Step 1 - Fit the system controller (if required)**

Ignore this Step if the system controller is already fitted.

- 1 Connect the power/communications cable from the APS to the RJ45 socket YS11 (RXP) socket on the back of the system controller.
- 2 Fit the system controller into the APS and tighten the retaining screw.

See the diagram on page [2](#) for position of system controller.

Step 2 - Check polarity

The APS can be configured for either positive earth or negative earth operation.

- 1 Remove top cover if fitted.
- 2 Check the polarity label on the dc common bus bar(s).
 (+) on the common bar(s) indicates positive earth. (-) indicates negative earth.
- 3 If the polarity of the APS matches the equipment at the site then no further action is required.
- 4 If the polarity of the APS is not correct for the equipment to be powered then contact your Eaton dc product supplier for advice (see Worldwide Support on page [103](#)).

Step 3 - Check position of mounting brackets

APSs are pre-assembled with 19-inch rack-mounting brackets as shown in the following diagram. If required, the brackets can be moved to alternative positions to reduce the effective depth of the unit.

Rack-mounting brackets are also available for use in 23-inch wide racks.

- 1 Remove top cover if fitted.
- 2 Undo the two screws holding each bracket.
- 3 Refit the brackets at the required location. Tighten the screws.

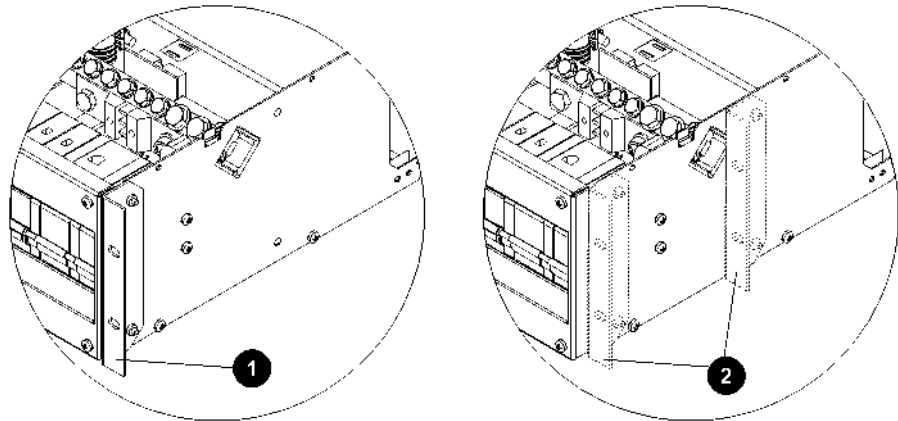

- ❶ Rack-mounting bracket (available for 19-inch and 23-inch wide racks) ❷ Alternative bracket mounting positions

Step 4 - Install Load circuit breakers (if required)



If the Load circuit breakers are already fitted then ignore this task.

The current rating of the MCBs must be derated to 80%.

- 1 Remove the dc distribution front cover and top cover (if fitted).
- 2 Fit the load MCBs onto the load tooth-comb bus (start at the right-hand end) and clip onto the DIN rail. Tighten the bottom MCB terminals.
- 3 Cut the load fuse fail detect wires (from the fuse fail alarm board on the APS) to the correct length to reach the MCBs.

There is one load fuse fail detect wire for each load MCB. These wires are thinner than the battery fuse fail detect wires.

- 4 Connect the wires to the top terminals of the MCBs and tighten terminal to hold the wire in place.
- 5 Fit MCB blanks to cover any unused positions.
- 6 Switch OFF all MCBs.

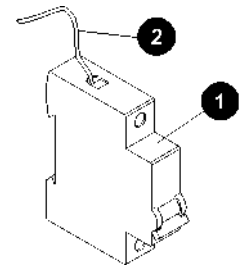

- ❶ Load MCB
❷ Load fuse fail detect wire from fuse fail alarm board.

Step 5 - Install Battery circuit breakers (if required)



If the Battery circuit breakers are already fitted then ignore this task.

The current rating of the MCBs must be derated to 80%.

- 1 Place the battery MCBs side-by-side (see following diagram).
- 2 Use the battery fuse fail detect loop wire to connect the auxiliary switches in series.

Use the auxiliary switch terminals that will be closed when the MCB is ON.

- 3 Fit the MCBs onto the battery tooth-comb bus (at the right hand end) and clip onto the DIN rail.

- 4 Tighten the bottom MCB terminals.
- 5 Connect the battery fuse fail detect wires to the MCB auxiliary switches (see following diagram). Tighten the terminals.
- 6 Fit MCB blanks to cover any unused positions.
- 7 Switch OFF all MCBs.

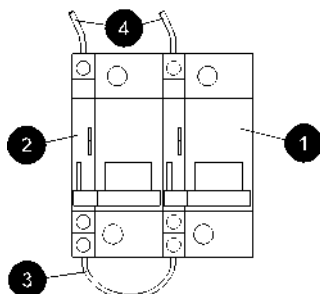

- 1 Battery MCBs (front view)
- 2 Auxiliary switches
- 3 Fuse fail detect loop wire
- 4 Battery fuse fail detect wires

Step 6 - Check if the APS ac and dc earths are bonded



There are two options: ac and dc earths bonded or separated.

- 1 Check if the APS ac and dc earths are bonded:
 - Remove top cover (if fitted).
 - If the ac-dc earth link screw (at one end of the dc common bar) is visible (see following diagram) then the ac and dc earths are bonded. This is the recommended, factory standard arrangement.
 - If the screw is not visible then the ac and dc earths are separated.
- 2 If the arrangement of the ac and dc earths is as required, no further action is required.
- 3 If the arrangement of the ac and dc earths is not as required, follow the procedure in Earth Bonding on page 87.

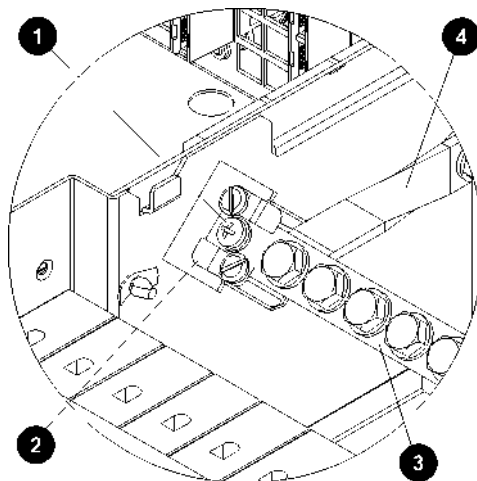

- 1 AC-dc earth link screw
- 2 Stand-off
- 3 dc common bar
- 4 Common bus

Procedure complete

Task 3 - Connect the AC Supply Cable

If the APS has pre-fitted ac cord(s) then ignore this task.



- If the APS dc power system is to be installed in a location where the ambient temperature may rise above 50° (122°F), then V90 rated cable must be used for the ac connections.

Step 1 - Check ac rating of the APS



See the diagram on page [2](#) for location of ac rating label.

Step 2 - Remove covers



- 1 Remove the ac terminal cover (see the diagram on page [3](#)).
- 2 If ac MCB(s) fitted, remove the distribution front cover and remove the top cover (if fitted).

Step 3 - Check the connection of the ac terminals



Check the ac terminals on the APS are connected to suit the type of ac supply. Refer to the ac connection diagrams in Step 6.

Access Power Solutions dc power systems can only be connected to one of the following:

AC source	Voltage (nominal)*	AC MCB (if fitted)
1-phase, neutral and Protective Earth (PE)	220-240V phase-neutral	1-pole
2-phase and PE	208V phase-phase	2-pole (linked)
3-phase, neutral and PE	220-240V phase-neutral	3-pole
3-phase and PE	208V phase-phase	3-pole (linked)



*See Specifications on page [71](#) for the ac voltage range.

Step 4 - Prepare the ac supply cable



- 1 Select ac supply cable to suit the ac supply source, the maximum ac current (see Specifications on page 71) and in accordance with the local wiring regulations.
- 2 Route the ac supply cable from the ac supply point into the rack. Then bring the cable through the front of the rack to the APS.
Do not terminate at the ac supply point at this stage.

- 3 At the APS end, cut the conductors to suit the positions of the terminals (and ac MCB(s) if fitted).
 Ensure the earth conductor is 30-50mm (1¼ - 2 inches) longer than the longest phase or neutral conductor.

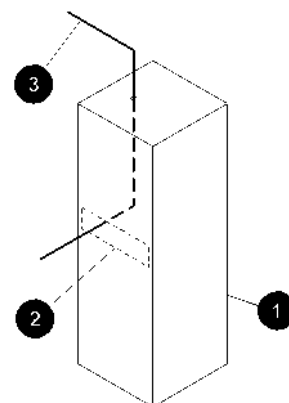

- 1 Rack cabinet
- 2 Proposed position of APS
- 3 AC cable from supply point (top or bottom entry into rack as required).

Step 5 - Terminate the earth conductor at APS



- 1 Position the APS in front of the rack.
- 2 Terminate the earth conductor with an M6 crimp lug.
 Ensure the ferrule of the crimp lug covers all strands of wire.
- 3 Connect the earth conductor to the earth termination point next to the ac terminals (see the diagram on page 3).

Step 6 - Terminate the phase and neutral (if used) conductor(s) at APS



- 1 If ac MCB(s) fitted then connect the phase conductor(s) to the MCB(s).
 Ensure the insulating card covers the MCB terminal(s).
- 2 If no ac MCB(s) fitted then terminate the phase conductor(s) with M4 crimp lug(s) and connect to the ac terminal(s) according to the following diagram that corresponds to the ac supply source.
 Ensure the ferrules of the crimp lugs cover all strands of wire.
- 3 If fitted, terminate the neutral conductor with an M4 crimp lug and connect to the ac terminal according to the following diagram that corresponds to the ac supply source.
 Ensure the ferrules of the crimp lug covers all strands of wire.

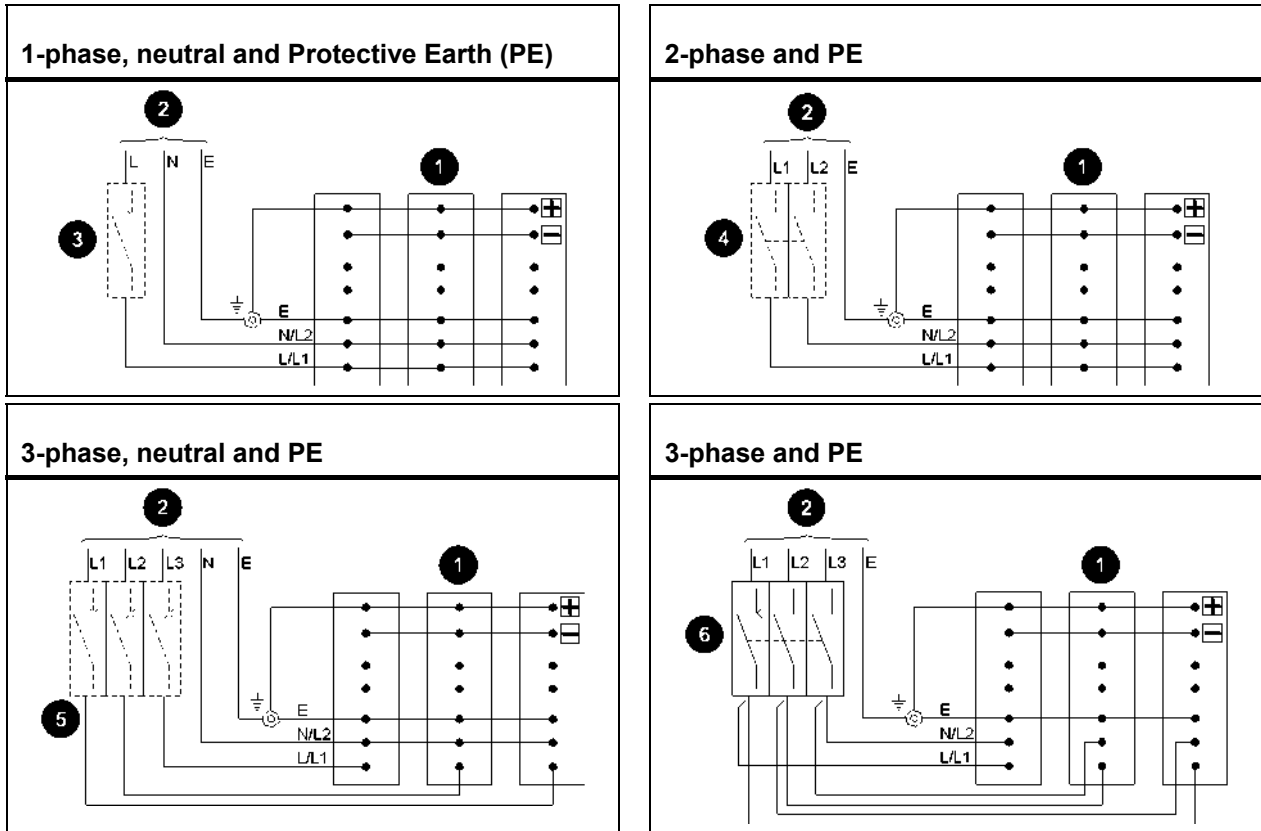

- ❶ Rectifier modules
- ❷ AC supply
- ❸ Optional 1-pole ac MCB
- ❹ Optional 2-pole (linked) ac MCB
- ❺ Optional 3-pole ac MCB
- ❻ 3-pole (linked) ac MCB
- ☐ Positive earth system shown.

Step 7 - Check terminations, secure cables and test insulation



- 1 Check all terminations are correct and are tightened.
- 2 Secure the cable with cable ties to ensure there is no strain on the terminals.
☐ See the diagram on page 3 for the location of the cable tie points.
- 3 Replace the ac terminal cover.
☐ Check all conductors to the ac terminals pass through the ac cable entry gland.
- 4 Test the insulation resistance of the conductors according to local ac wiring regulations.

Procedure complete

Task 4 - Mount the APS in the Rack

Step 1 - Check clearances



APSs require the following minimum clearances:

- Front Clearance - 600mm (24") for access and unrestricted air intake.
- Rear Clearance - 50mm (2") from back of rack, other equipment and cables to allow air escape route for optimum system cooling.
- Top Clearance - 1U (44.45mm / 1¾") minimum from other equipment in the rack. Recommended for access to cable terminations.

Step 2 - Fit cage nuts



Fit cage nuts in the correct positions to match the screw holes in the APS rack mounting brackets.

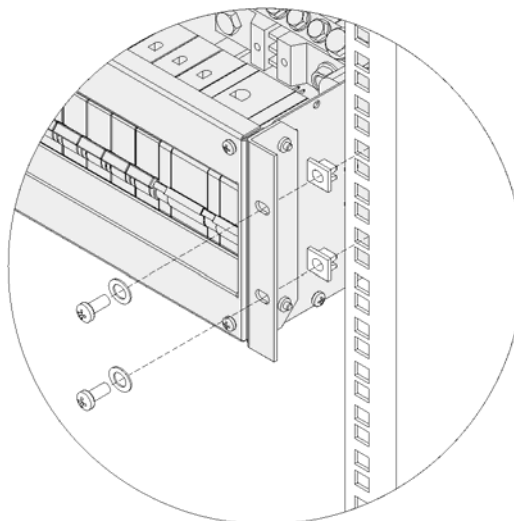

Step 3 - Mount the APS



- 1 Carefully feed the ac supply cable or cord(s) into the rack.
- 2 Lift the APS to the correct position in the rack.
 - A suitable mechanical support or a second person must support the weight of the APS.
- 3 Attach the APS using four rack mounting screws. Tighten the screws.

Procedure complete

Task 5 - Connect the DC Load and Battery Cables



- If the APS dc power system is to be installed in a location where the ambient temperature may rise above 50°C (122°F), then V90 rated cable must be used for the dc load and battery connections.

Step 1 - Remove covers



- 1 Remove the distribution front cover.
- 2 Remove the top cover (if fitted).

Step 2 - Connect dc common busbar to earth



Install a separate conductor from the dc common busbar to earth. This conductor must be rated to carry the combined fault current of all battery strings.



If this conductor is not installed then battery fault current will be carried by the ac-dc earth link and the ac earth conductor which are typically too small for such currents.

Step 3 - Connect battery cables



- Always check that the battery cables have been terminated to the correct system polarity BEFORE connecting the batteries or closing the battery disconnect device.
- Connecting batteries to the system with incorrect system polarity will void all warranty claims.



- 1 Select battery cable to suit the maximum battery current and voltage drop requirements.
- 2 Route the battery cables to the APS.
 - If the optional top cover is used then route the cables under the cable tie rod.*
- 3 Terminate the battery common cable(s) with an M8 crimp lug.
- 4 Connect the battery common cable(s) on the common bar at the battery termination points. Tighten according to the Standard Torque Settings on page [68](#).
- 5 Terminate the battery live cable(s) at the battery MCB(s). Tighten the terminals.
 - The current rating of the MCBs must be derated to 80%.*
- 6 Switch OFF all MCBs.

Step 4 - Connect load cables



- 1 Select load cable to suit the dc load currents and voltage drop requirements.
- 2 Route the load cables to the APS.
 - If the optional top cover is used then route the cables under the cable tie rod.
- 3 Terminate the load common cable(s) with an M6 crimp lug.
- 4 Connect the load common cable(s) on the common bar at the load termination points. Tighten according to the Standard Torque Settings on page 68.
- 5 Terminate the load live cable(s) at the load MCB(s).
 - The current rating of the MCBs must be derated to 80%.
 - Ensure that the fuse fail detection wires are properly terminated as shown in the following diagram.
- 6 Tighten the MCB terminal(s).
- 7 Switch OFF all MCBs.

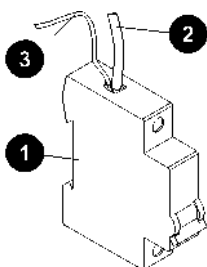

- ① Load MCB
- ② Load live cable
- ③ Fuse fail detection wire (connected to fuse fail alarm board)

Step 5 - Check terminations, secure cables and test insulation



- 1 Check all terminations are correct and are tightened.
- 2 Secure the cables with cable ties to the cable tie rod to ensure there will be no strain on the terminals.
- 3 Test the insulation resistance of the cables.

Procedure complete

Task 6 - Install the Batteries



- Always check that the battery cables have been terminated to the correct system polarity BEFORE connecting the batteries or closing the battery disconnect device.
- Connecting batteries to the system with incorrect system polarity will void all warranty claims.

Installation procedure

Step 1 - Install the batteries



Follow the battery supplier's/ manufacturer's installation instructions.

Step 2 - Connect Mid-point Monitoring sense wires (SC200 only)



The Mid-point Monitoring sense wires must have short-circuit protection fitted close to the battery terminals. Use the Battery Mid-point Monitoring kits from Eaton (see Spare Parts on page 68) or equivalent.

1 Connect a Mid-point Monitoring sense wire to the middle interconnecting link on each string of batteries (see following diagram).

Connect the wire from XH12A pin 1 to string 1, and so on.

If there is an odd number of 2V cells per string then connect the sense wires to the interconnecting link on the side of the central cell closer to the Common battery terminal.

2 Tighten the terminals according to the battery supplier's/ manufacturer's installation instructions.

3 Insulate any un-connected sense wires.

4 Secure all sense wires to avoid any strain on the terminations.

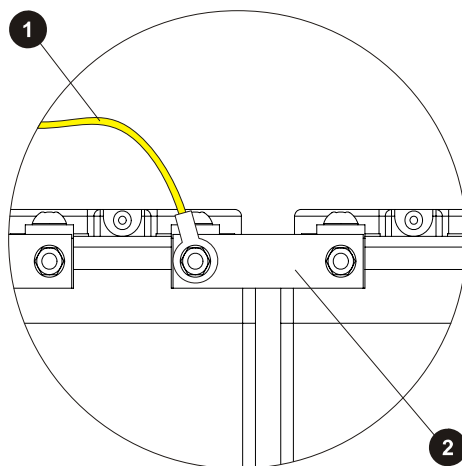

- 1** Mid-point Monitoring sense wire from XH12A on the input/output board
- 2** Middle interconnecting link

Procedure complete

Task 7 - Mount the Battery Temperature Sensor

The APS is supplied with a battery temperature sensor and standard 2m (6.5 feet) long cable, already connected to the IOBGP input/output (I/O) board to measure the ambient air temperature around the batteries. This is required for the temperature compensation control process.

Step 1 - Connect and route cable



1 Connect the temperature sensor cable supplied to socket XH7 on the I/O board.

If required extend the cable using an RJ45 patch cable and in-line joiner. Recommended maximum cable length is 20m (65 feet) because of noise considerations.

2 Route the temperature sensor cable to the middle battery shelf or the middle of the external battery stand.

Do not run the sensor cable along ac supply cables. Interference may cause false readings.

Step 2 - Fix sensor

Fix the sensor above the batteries. To avoid false readings:

- Do not attach the sensor to a battery case, battery cables, terminals or interconnecting bars.
- Do not expose the sensor to direct sunlight, or air movements from air-conditioning systems or open windows.

Procedure complete**Task 8 - Connect External Input/Output Cabling (if required)**

The APS is fitted with an input/output (I/O) board. This provides a number of digital inputs and digital outputs (relays). See Input/Output Board on page 6 for details of how the I/O board can control and monitor external devices.

If no external devices are to be connected then ignore this task.

Step 1 - Access the I/O board

Remove the top cover (if fitted).

Step 2 - Terminate the cabling

- Connect only voltage-free switch or relay contacts to Digital Inputs.
- Do not exceed the voltage and current limits of the digital output relay contacts.
- For wire size, alarm relay and digital input specifications see Specifications on page 72.

- 1 Route the cabling through the access hole to the terminal blocks on the I/O board.
 -  Leave a loop of at least 300mm (12") of cable to allow the I/O board to be withdrawn with the wires attached.
- 2 Visually check the cable for damage.
- 3 Test the insulation and continuity of the cabling.
- 4 Terminate the cabling as in the following diagrams.
- 5 Use cable ties to secure the cable and prevent strain on the connector.

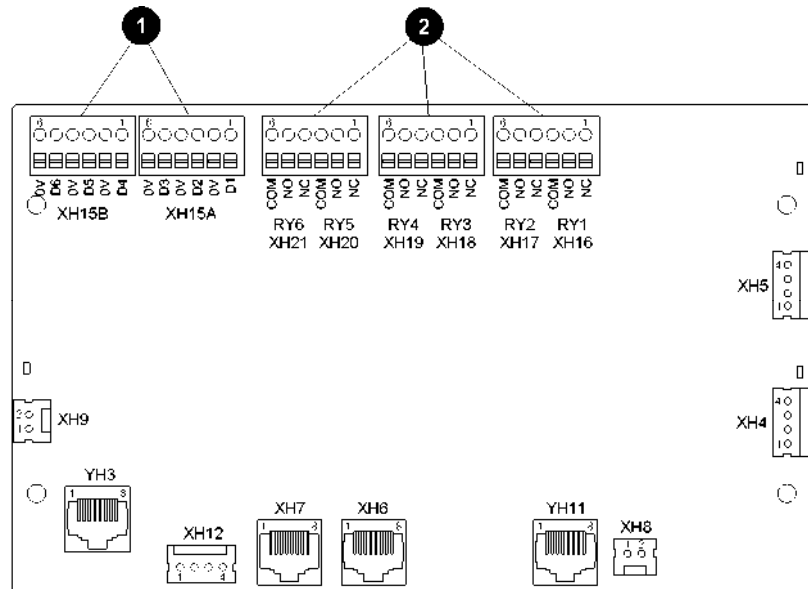
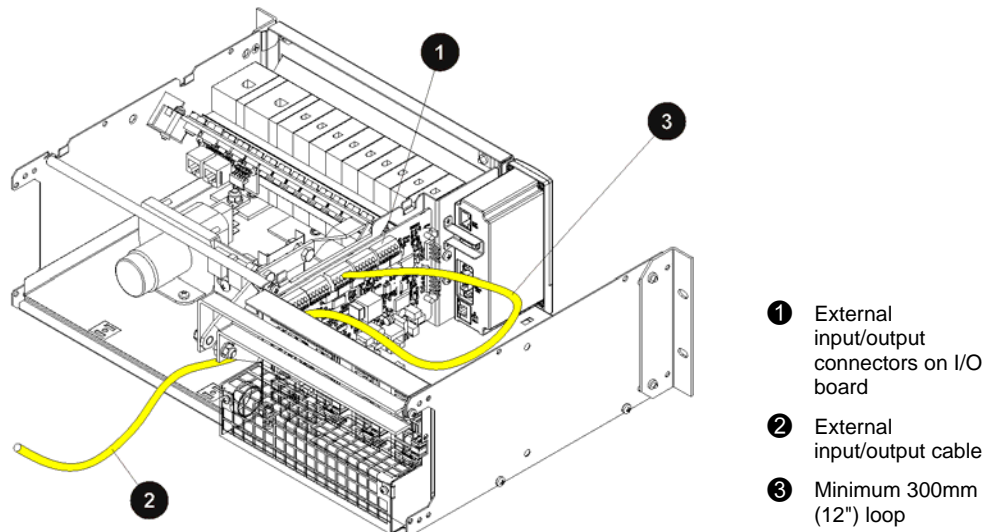

Step 3 - Refit top cover (if removed)



Replace the top cover (if fitted and all installation tasks are completed).

Step 4 - Set up SC200 or SC100



Configure the inputs and outputs after completing the installation and all the Startup Tasks on page 34.



For configuration details see Digital Inputs and Digital Outputs in the System Controller Operation Handbook.

Procedure complete

For details about setting up and testing see Input/Output (I/O) in the System Controller Operation Handbook.

Task 9 - Connect Additional Input/Output (if required - SC200 only)

If additional input/outputs are required then SiteSure-3G modules can be connected to the APS (SC200 only). A SiteSure-3G input/output module has the following features.

SiteSure-3G	
Digital Inputs	10
Digital Outputs (relays)	6
Analog Inputs (0 to 10V)	4
Current Sense Inputs	3
Temperature Sense Inputs	2
Bus Voltage Input (0-60V)	1
Enclosure	Wall or panel mounting plastic case

For further information refer to the SiteSure-3G Installation and Operation Guide (see Related information on page i).



Connect the SiteSure-3G cable to a spare RJ45 socket (S1, S2 or S3) on the Voltage Feed Module board. See the diagram on page 2 for socket location.

Task 10 - Connect to the AC Supply Point



- A suitably qualified electrician familiar with local wiring regulations must carry out the ac connection.

Step 1 - Replace all covers on the APS



Step 2 - Connect at the ac supply point



- 1 Check the ac supply point is isolated.
- 2 Connect the cord(s) or cable to the ac supply point, or fit plug(s) to the cord(s) to match the wall receptacle/socket(s), as required.
 Follow the manufacturer's instructions and local wiring regulations.
- 3 Label the connection at the ac supply point.

Step 3 - Check terminations, secure cable and test insulation



- 1 Check all terminations are correct and are tightened.
- 2 Secure the cord(s) or cable to ensure there is no strain on the terminals.
- 3 Test the insulation resistance of the conductors according to local ac wiring regulations.

Procedure complete



Do not switch on the ac supply at this stage.

Installation Completed

Installation of the APS is now complete. Follow the instructions in Start-Up on page [34](#) to make the system operational.

Overview

Topic	Page
Start-Up Tasks	34
Task 1 - Inserting the Rectifiers	34
Task 2 - Pre-Power-Up Checklist	35
Task 3 - Applying AC Power	35
Task 4 - Configuring the DC Power System	36
Task 5 - Applying DC Power to Battery and Load	37
Start-Up Completed	38

Start-Up Tasks

Complete all the Installation tasks (see details on page [16](#)) before starting these Start-Up tasks.

Complete the Start-Up tasks in the following order:

Task	Description	Reference
1	Insert the Rectifiers	See details on page 34
2	Complete the Pre-Power-Up Checklist	See details on page 35
3	Apply AC Power	See details on page 35
4	Configure the dc power system	See details on page 36
5	Apply dc Power to Battery and Load	See details on page 37

Task 1 - Inserting the Rectifiers



- Do NOT install the rectifiers until the room has been cleaned and is dust free.
- Do NOT switch on the ac supply at this stage.

Step 1 - Unpack the rectifiers



Unpack the rectifiers and inspect them carefully for possible transport damage. Report any damage immediately using a completed Equipment Incident Report on page [101](#).

Keep the original packaging to return a rectifier for replacement or repair, if required.

Step 2 - Fit first rectifier



- 1 Align the rectifier with the left side of the shelf.
- 2 Push in the rectifier until the retaining screw contacts the shelf.
- 3 Check the rectifier's rear connector is correctly aligned with the shelf connector, or damage may occur.
- 4 Tighten the retaining screw to 1.5Nm (13.3 inch-pounds). This will locate the rectifier in its rear connector.

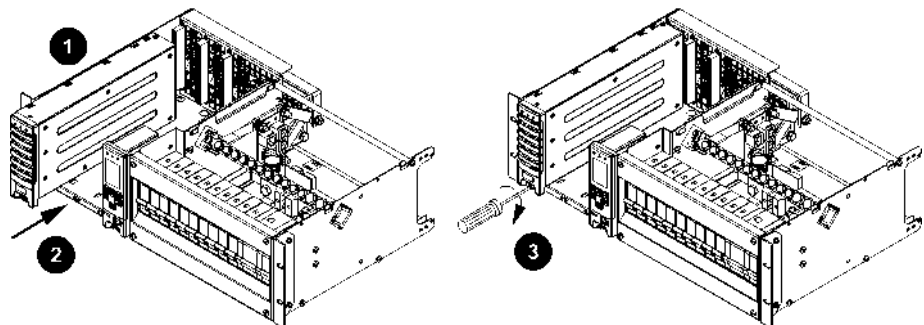

Step 3 - Repeat for other rectifiers or fit blank panels



If not already fitted, fit rectifier blank panels in any vacant rectifier positions.

Procedure complete

Task 2 - Pre-Power-Up Checklist

Complete the checklist to confirm initial work is complete before progressing further.

<input type="checkbox"/>	All cabling is installed, securely tied and correctly insulated
<input type="checkbox"/>	Upstream surge protection is fitted (see Input Transient Protection on page 83)
<input type="checkbox"/>	Earth bonding is correct (see details on page 19)
<input type="checkbox"/>	Battery and load cabling has the correct polarity
<input type="checkbox"/>	A registered electrician or other suitable approved person has checked the integrity of the installed cabling
<input type="checkbox"/>	All panels are in place and all empty rectifier slots are covered with blanking panels
<input type="checkbox"/>	AC isolator and all ac MCBs (if fitted) are switched off
<input type="checkbox"/>	All dc distribution MCBs are switched off and/or fuses removed
<input type="checkbox"/>	AC supply is isolated at each point of isolation leading back to the ac supply point
<input type="checkbox"/>	Batteries are electrically isolated from the dc power system
<input type="checkbox"/>	The site is clean

Task 3 - Applying AC Power



- A registered electrician (or suitably qualified person) must check the integrity of the installed cabling, BEFORE the dc power system is powered up.

- 1 Switch on the AC supply.
 - All rectifiers start up (after the startup delay).
 - The rectifier alarm LEDs will turn on for a short time.
 - The SC200 or SC100 system controller will turn on (green Power On LED is on) when the rectifiers start.
 - During start-up of the system controller the rectifier yellow alarm LEDs will flash until the rectifiers are registered.

- 2 After start-up of the system controller:
 - Press any key on the system controller to silence the alarm.
 - ☐ Depending on the configuration file settings, one or both alarm LED(s) may be on and the system controller may display some system alarm messages. This is normal. For an explanation of alarm messages see Alarm Descriptions in the System Controller Operation Handbook.
 - The LCD display module shows the summary screen. See details on page [41](#).
 - ☐ If no load or battery is connected the current will be 0A.
 - If fitted and enabled, the LVD(s) operate.
 - 3 Check all rectifiers are running and only the rectifier green Power On LEDs are on (no alarm LEDs).
 - On the system controller keypad select *Menu > Rectifiers*. See details on page [75](#). Check that all rectifiers are registered.
- ☐ If any problems see Troubleshooting on page [50](#).

Task 4 - Configuring the DC Power System

The operational settings of the dc power system are stored in a configuration file loaded into the SC200 or SC100 system controller. See details on page [40](#).

The system controller is supplied pre-loaded with a configuration file. If this configuration file has been customized for the site then no further configuration changes will be necessary.

If the configuration file has not been customized for the site then check the following settings and change if necessary.

- ☐ Other configuration settings can be changed after all Start-Up tasks are complete. Refer to the System Controller Operation handbook (see Related Information on page [i](#)) for details on how to customize the system's configuration.

Parameter	Action	Where to find
Float Voltage	Set to the value recommended by the battery manufacturer.	SC100: Menu > Configuration > System > Edit > Float Voltage
		SC200: Control Processes > Voltage Control > Float Voltage
		DCTools: Control Processes > Voltage Control
Battery Capacity	Set to the rated 10 hour capacity of the installed battery strings, or set to zero if no battery connected.	SC100: Menu > Configuration > System > Edit > Battery Capacity > Edit
		SC200: Battery > Battery > Battery Capacity
		DCTools: Batteries
Cells Per String	Set to the number of cells in each battery string (if battery connected).	SC100: Menu > Configuration > Temp Compensation > Edit > Cells Per String
		SC200: Battery > Battery > Number of Cells
		DCTools: Batteries

Parameter	Action	Where to find	
Temperature Compensation	Enable (if battery and battery temperature sensor connected) and check the settings.	SC100:	Menu > Configuration > Temp Compensation > Edit
		SC200:	Control Processes > Temp. Compensation > Enable
		DCTools:	Control Processes > Temperature Compensation
Low Voltage Disconnect (LVD)	Enable (if LVD(s) installed and battery connected) and check the settings.	SC100:	Menu > Configuration > LVD1/LVD2
		SC200:	Battery > LVDs > LVD x
		DCTools:	Control Processes > LVD
System controller time (SC200 only)	Connect using Web to set correct time manually or connect using DCTools to synchronize to PC time. See details in the System Controller Operation Handbook.	Web:	Configuration > Time
		DCTools:	Configuration > Time > Time Synchronization

Task 5 - Applying DC Power to Battery and Load



Reverse Polarity

- Always check that the battery cables have been terminated to the correct system polarity BEFORE connecting the batteries or closing the battery disconnect device. Connecting batteries to the dc power system with incorrect system polarity will damage the rectifiers and void all warranty claims.

Step 1 - Check dc voltage and polarity



Check the dc output voltage and polarity of the power system and the battery string(s).

Step 2 - Connect batteries



- If connecting multiple battery strings then check the individual strings are of similar voltage.
- Switch on all Battery MCB(s) and/or fit the battery fuses.
- Check the Battery Fuse Fail alarm clears.
 - All Battery MCBs (including any unused MCBs) must be switched on to clear the alarm.
- Check the battery current. The actual value depends on the state of charge of the batteries.

Step 3 - Connect load



- 1 Switch on the Load MCB(s) and/or fit the Load fuses.
- 2 Check the equipment powers up and the Load Fuse Fail alarm clears.

Step 4 - Check the rectifier currents



- 1 Check the rectifier currents.
- 2 Verify the load current is as expected for the load and battery size.

Step 5 - Charge the batteries



- 1 Charge the batteries according to the battery manufacturer's recommendations.
- 2 If an Equalize charge is recommended by the battery manufacturer then follow the instructions.



Equalize increases the system voltage to the Equalize voltage for the Equalize duration. After the Equalize duration has expired, the dc power system voltage reverts to float voltage automatically.

Procedure complete

Start-Up Completed

Start-Up of the APS is now complete and the system is operational.

If a formal commissioning test is required then see the Commissioning check lists on page [89](#).

The System Controller Operation Handbook (see Related Information on page [i](#)) describes how to use the SC200 or SC100 system controller. See:

- *System Operation* to customize the system configuration settings, and
- *Communications* to setup the remote communications options.

For information on alarms, or operation problems see Maintenance on page [49](#).

Topic	Page
Configuration File	40
Starting the SC200 or SC100	41
SC200 or SC100 Operation using the Keypad and Screen	42
SC200 or SC100 Operation Using a PC/Laptop	44
SC200 or SC100 Identity Information	46

Configuration File

The operational settings of the dc power system are stored in a configuration file loaded into the SC200 or SC100 system controller.

The SC200 or SC100 is supplied pre-loaded with a configuration file. If this configuration file has been customized for the site then no further configuration changes will be necessary.

Otherwise, it is important that the settings of this configuration file are checked and changed as required for site-specific conditions. In particular, settings that may affect the performance and life expectancy of the battery must be checked and set according to the battery manufacturer's recommendations.

Some settings in the configuration file can be edited using the system controller's keypad (see details on page [42](#)), or all settings can be edited using a PC/laptop with DCTools/Web (see details on page [44](#)) or remotely, see Communications Options in the System Controller Operation Handbook.

Backup and Restore

The configuration file settings in the SC200 or SC100 can be saved to (Backup) or loaded from (Restore) a PC/laptop using DCTools/Web.

Backup and Restore can be used to:

- Load a standard (master) configuration file into an SC200 or SC100 for customization.
- Copy a customized configuration file from one SC200 or SC100 to others (at similar sites).
- Save a copy of a customized configuration file. This is recommended in case the SC200 or SC100 has to be replaced.

► To use DCTools for Backup and Restore

- 1 Connect to the SC200 or SC100 with DCTools. See details on page [44](#) or see Communications Options in the System Controller Operation Handbook.
- 2 In DCTools go to *File > ICE Backup/Restore* and follow the prompts.



The saved file does not include site specific settings including Site Identity, IP Address, S3P Address, battery characterization data.

► To use a web browser for Backup (SC200 only)

- 1 Connect to the SC200 via a web browser. For details see Ethernet Communications in the System Controller Operation Handbook.
- 2 Go to *Tools*.
- 3 Select *Backup Tool*.
- 4 Select the file type:
 - **System Snapshot (*.dcs):** Configuration file including site specific settings.
 - **Configuration (*.dcc):** Configuration file without site specific settings - Site Identity, IP Address, S3P Address, battery characterization data).
- 5 Click *Proceed* to Backup the configuration.

► **To use a web browser for Restore (SC200 only)**

- 1 Connect to the SC200 via a web browser. For details see Ethernet Communications in the System Controller Operation Handbook.
- 2 Go to *Tools*.
- 3 Select *Restore Tool*.
- 4 Select the file type:
 - **System Snapshot (*.dcs):** Configuration file including site specific settings.
 - **Configuration (*.dcc):** Configuration file without site specific settings - Site Identity, IP Address, S3P Address, battery characterization data).
 - **Fragment (*.dcf):** Restore part of a configuration file (such as battery characterization data).
- 5 Click *Next*, then select a file name to Restore a configuration.

Starting the SC200 or SC100

When dc power is applied to the SC200 or SC100 (via the RXP connector YS11) the start-up sequence begins.

SC200

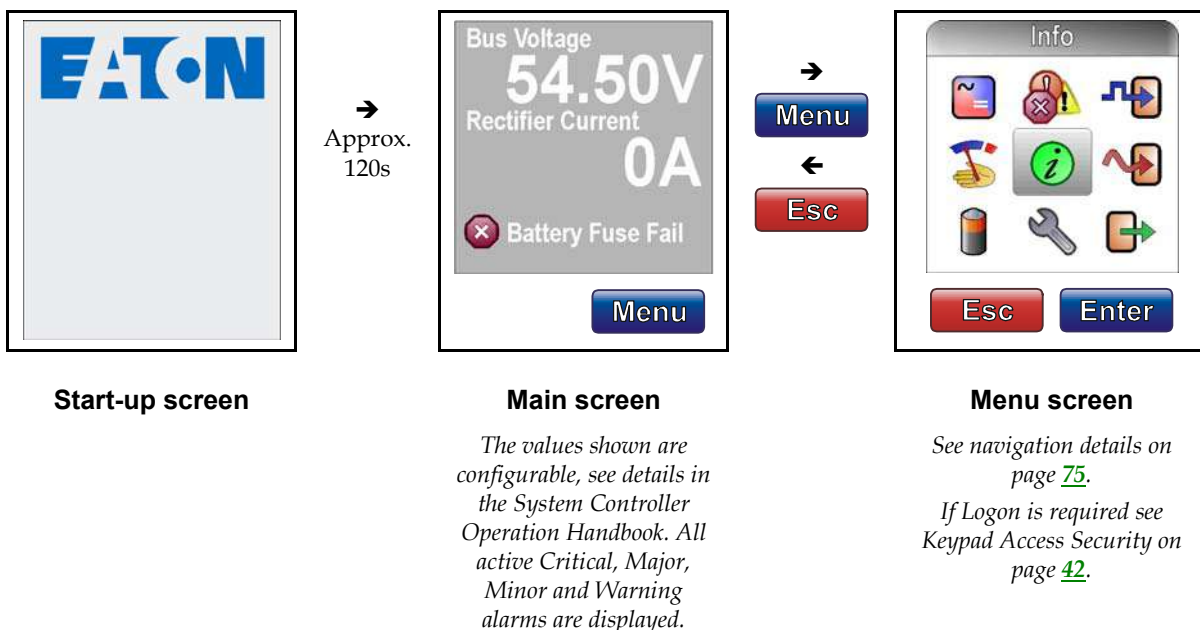

SC100



Start-up screen

→
Approx
20s

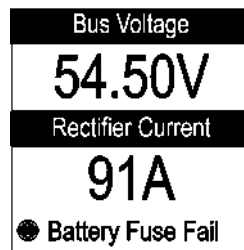

First status screen

All active alarms are displayed.

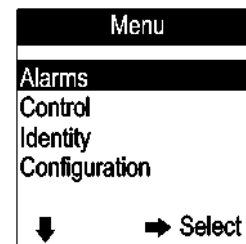

Main menu

See details on page [76](#).

SC200 or SC100 Operation using the Keypad and Screen

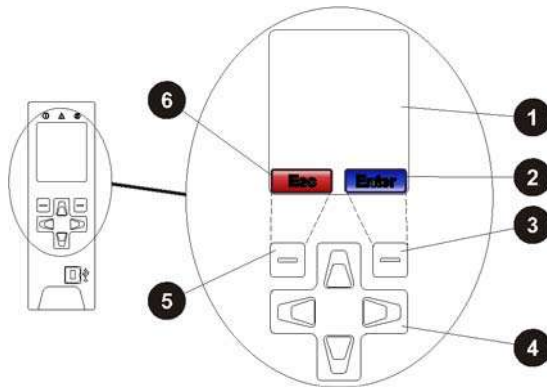

- ① LCD display
- ② Soft key 1 label (SC200 only)
- ③ Soft key 1 (SC200 only)
- ④ Navigation keys (Up - Down - Left - Right)
- ⑤ Soft key 2 (SC200 only)
- ⑥ Soft key 2 label (SC200 only)

Keypad Access Security

SC200 System Controller

This feature prevents accidental or unauthorized changes to settings from the SC200 keypad.



All access to change an SC200's settings will be lost if:

- All communications are disabled (see S3P Access and HTTP/HTTPS Access in the System Controller Operation Handbook), and
- Keypad access is *Read Only*, or *PIN Protected* and the keypad access PIN is lost.

The SC200 will continue to function, but no configuration changes can be made. Contact your Eaton dc product supplier or Eaton for advice (see Worldwide Support on page [103](#)).

► **To use DCTools/Web to enable/disable keypad access**

- In DCTools/Web go to *Communications > Front Panel*.
- Set *Access* to:
 - *Unprotected* - keypad access is allowed to view and change parameters, or
 - *Read Only* - keypad access is allowed to view parameters only, or
 - *PIN Protected* - keypad access is allowed to view and change parameters if the correct 4-digit number is entered in the *Access PIN* field. Otherwise, *Read Only* access is allowed.

► **To use the SC200 when access is set to PIN Protected**

- At the Main Screen press *Menu*. The *Logon* screen appears.
- If the *Access PIN* is not known then press *Skip* to use the SC200 with *Read Only* access.
- If the *Access PIN* is known:
 - Use the Left and Right keys to access each digit position. Use the Up and Down keys to change the digits.
 - When the correct digits are entered, press *Logon*.

 *Keypad access will return to PIN Protected mode when the display returns to the Main Screen.*

SC100 System Controller

This feature prevents accidental or unauthorized changes to settings from the SC100 keypad.

► **To use DCTools/Web to enable/disable keypad access**

- In DCTools/Web go to *Communications*.
- Set *UI Access* to:
 - *Unprotected* - keypad access is allowed, or
 - *Protected* - keypad access is denied (can be temporarily over-ridden, see below).

► **To temporarily enable keypad access at the SC100 when access is set to Protected**

- Press *Up* and *Down* keys together for 5 seconds.

 *Keypad access is now temporarily enabled. Keypad access control reverts back to Protected mode after the display goes back to the Summary screen.*

Alarm Indicators

Visual indicators

 Power on LED (green)

 Minor Alarm LED (yellow)

 Critical/Major Alarm LED (red)

???

The system value cannot be displayed because of a failed, disconnected or unconfigured sensor.

Audible indicator

- One beep – indicates an invalid key press
- Three beeps every 2 seconds – refer to the alert message on the display (SC200 only)
- One beep every 2 seconds – Minor alarm is active
- Continuous sound – Critical/Major alarm is active

 *Critical/Major alarms always override Minor alarms.*

▶ **To stop the audible indicator**

- Press any key

 *The audible indicator will restart at the next active alarm or alert message.*

▶ **To enable/disable the audible alarm indicator**

Either:

- On SC200 go to: Alarms > Alarm Settings > Audible Alarms > Edit.
- or on SC100 go to: Menu > Configuration > Audible Alarm.

Or:

- In DCTools/Web go to: *Alarms > Alarm Configuration.*

 *When Disabled, the audible indicator will still indicate an invalid key press.*

SC200 or SC100 Operation Using a PC/Laptop

DCTools is configuration software for editing a system controller's configuration file (on-line) and monitoring the operation of Eaton's dc power systems. It is available free from www.powerquality.eaton.com/downloads.

Using DCTools via USB (SC200 only)

DCTools can be run on a PC/laptop connected to the SC200's USB port.

 *DCTools can also be run on a remote PC/laptop connected to the SC200's RS232 serial port (via a modem) or Ethernet port. For remote PC/laptop connection details see Communications Options in the System Controller Operation Handbook.*

Before you start you will need:

- The latest version of *DCTools* available from www.powerquality.eaton.com/downloads.
- A PC/laptop with USB port and USB A/B cable (RadioShack 55010997, Jaycar WC7700, or equivalent).

▶ **To connect a PC/laptop to the SC200:**

- 1 Download the latest version of *DCTools* from www.powerquality.eaton.com/downloads.
- 2 Install *DCTools* on the PC/laptop.

- 3 Connect a USB A/B cable from a USB port on the PC/laptop to the USB port on the SC200.
 See the diagram on page 5 for location of the USB port.
- 4 DCTools will now connect to the SC200.
 If connection is not successful refer to DCTools Help (press F1) or Troubleshooting on page 50.
- 5 For details of the SC200 control and monitoring functions available via DCTools see System Operation in the System Controller Operation Handbook.
 For help using DCTools press F1.

Using DCTools via RS232

DCTools can be run on a PC/laptop connected to the SC200 or SC100's RS232 port.

- For remote PC/laptop connection details see Communications Options in the System Controller Operation Handbook.

Before you start you will need:

- The latest version of DCTools available from: www.powerquality.eaton.com/downloads.
- A PC/laptop with USB port (for use with SC200) or RS232 port (for use with SC100)

► To connect a PC/laptop to the SC100:

- 1 Download the latest version of DCTools from: www.powerquality.eaton.com/downloads.
- 2 Install DCTools on the PC/laptop.
- 3 Connect a null-modem cable from the COM1 RS232 port on the PC/laptop to the RS232 connector on the SC100.
 See the diagram on page 5 for location of the RS232 connector on the SC100. Ensure the cable is secured so that no force is applied to the RS232 plug on the SC100 as this may damage the connector.
 If COM1 port is not available or for more details see Direct RS232 Communications in the System Controller Operation Handbook.
- 4 Start DCTools to open the Connection List. Check the box for the COM1 connection.

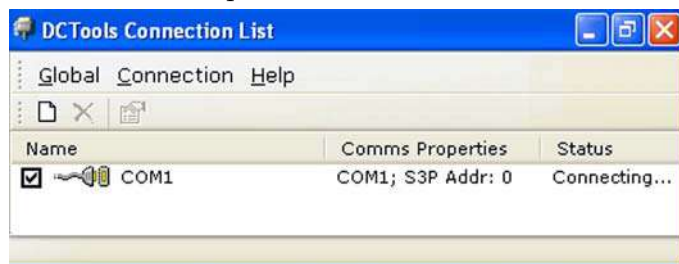

- 5 DCTools will now connect to the SC100.
 If connection is not successful refer to DCTools help (press F1) or Troubleshooting on page 50.

- 6 For details of the SC100 control and monitoring functions available via *DCTools* see System Operation in the System Controller Operation Handbook.

 For help using *DCTools* press F1.

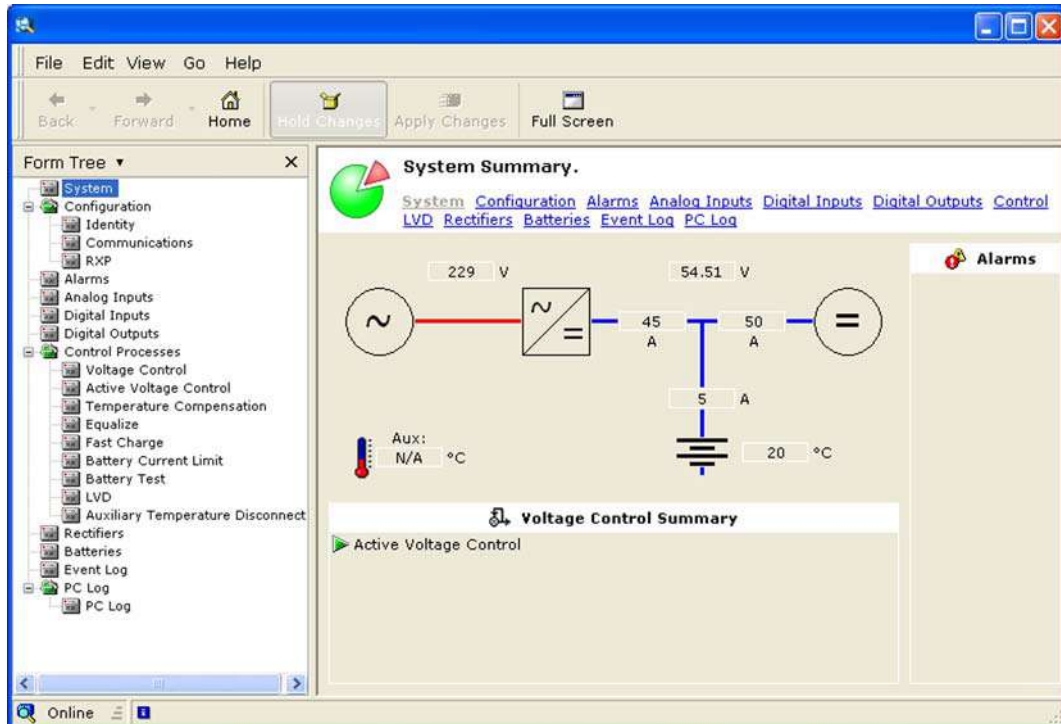

SC200 or SC100 Identity Information

The following identity information is stored in the SC200 or SC100.

Parameter	Description	Where to find:
Serial Number	The SC200 or SC100 serial number (factory set).	SC100: Menu > Identity > SC100 Identity
Software Version (App Version)	The version of the embedded software in the SC200 or SC100 (factory set).	SC200: Settings > Info DCTools/Web: Configuration > Identity

If required, the following site specific information can be stored in the SC200 or SC100 to assist site management.

Parameter	Description	Where to find:
System Manufacturer	The manufacturer of the dc power system.	
System Type	The APS model number.	
System Serial Number	The APS serial number.	
System Location	Location of APS at the site.	
Site Name	Name of the site.	DCTools/Web: Configuration > Identity
Site Address	Address of the site.	
Site Notes	Any notes relevant to site access, location or other matters.	
Contact	Contact name, phone number, etc.	
Configuration Name	Reference name of the configuration file in the SC200 or SC100.	

Overview



- The APS contains hazardous voltages and hazardous energy levels. Before undertaking any maintenance task refer to the Warnings on page [12](#).
- If a maintenance task must be performed on a "live" system then take all necessary precautions to avoid short-circuits or disconnection of the load equipment, and follow any "live-working" instructions applicable to the site.
- Only perform the maintenance tasks described in the Maintenance chapter. All other tasks are classified as Servicing. Servicing must only be performed according to specific instructions and only by personnel authorized by Eaton. This includes disassembly and/or servicing of any modules.
- For further information on Servicing contact your local Eaton dc product supplier, or refer to the contact details on page [103](#).

Topic	Page
Troubleshooting	50
Replacing or Adding a Rectifier	58
Replacing or Adding a Load MCB	59
Replacing the System Controller	60
Replacing the Input/Output Board	63
Battery Mid-point Monitoring (String Fail) Alarm (SC200 only)	65
Battery Disposal and Recycling	65

Troubleshooting

Use the table to troubleshoot minor installation and operational problems. For additional assistance see contact details on page [103](#). Return items for replacement or repair with a completed Equipment Incident Report on page [101](#).

System Problems

Problem	Possible Cause	Required Action
All rectifiers are off (no LEDs on) and system controller display is blank.	AC supply to the system is off and batteries are not connected or are fully discharged.	Restore ac supply.
Green LED of one or more rectifiers is off.	AC supply to rectifier(s) off or one or more phases are off.	Restore ac supply.
	Rectifier(s) not fully inserted.	Insert rectifier and tighten retaining screw.
	Internal rectifier fault.	Remove the rectifier and insert another one in the same slot. If second rectifier fails to start then there is a fault with the rectifier position. Check ac connections. If the second rectifier operates normally, the first rectifier is faulty and must be returned for service.
All rectifier LEDs flash.	The rectifier <i>Identify</i> function.	Normal operation. See details in the System Controller Operation Handbook.
Rectifier yellow LED flashes	The system controller is starting.	Wait for system controller to complete start-up.
	Rectifier has not registered with the system controller.	Remove then re-insert the rectifier. Replace the rectifier with another rectifier. If second rectifier fails to register then there is a fault with the rectifier position. Check rectifier comms bus wiring. If second rectifier registers then first rectifier is faulty and must be returned for service.

Problem	Possible Cause	Required Action
Rectifier yellow LED on.	Rectifier power limit or current limit is active.	Power system is charging the batteries. If required, activate the Battery Current Limit control process.
	Load current exceeds the total rectifier capacity.	Install additional rectifiers.
	Rectifier temperature turndown is active due to low ac supply voltage or high ambient temperature.	Power system will return to normal operation when the ac supply voltage and/or ambient temperature are within the specified ranges. See Specifications on page 71 .
	Rectifier has been shut down. (Depending on model, rectifier may also click every 5-15 seconds.)	Normal operation. See details in the System Controller Operation Handbook. If required, restart the rectifier.
Rectifier red LED on.	Very high or low ac voltage, or ac supply failed.	Power system will return to normal operation when the ac supply voltage is within the specified range. See Specifications on page 71 .
	DC overvoltage	Remove and re-insert rectifier(s) or shut down and restart using <i>DCTools/Web</i> .
	Internal rectifier fault.	Replace the rectifier.
Low system output voltage (rectifiers not in current limit).	Rectifiers off.	Restore the ac supply.
	Battery Test and/or Temperature Compensation is active.	Disable active function(s) if not required.
	Incorrect float voltage setting at system controller.	Correct the float voltage setting of the system controller. Record new setting.
Low system output voltage and rectifier yellow LEDs are on (rectifiers are in current limit).	Load is too high for rectifier capacity.	Install additional rectifiers.
	Battery is recharging after ac supply failure.	Check battery has recharged within expected time.

Problem	Possible Cause	Required Action
High system output voltage.	Equalize, Fast Charge and/or Temperature Compensation is active.	Disable active function(s) in system controller if not required.
	Incorrect float voltage setting at system controller.	Correct the float voltage setting of the system controller. Record new setting.
	Faulty rectifier.	Locate the rectifier with the highest output current and remove this one first. If the first rectifier removed is not faulty, remove each of the remaining rectifier modules one at a time, until the faulty rectifier is found. (The output voltage returns to normal when faulty rectifier is removed.) Replace faulty rectifier with one that is working. Return the faulty rectifier for service.
System has no dc output (rectifiers are on).	Load MCB open.	Switch on the required load MCB(s).
System has no battery input	Battery fuse or MCB open.	Check for open battery fuse or MCB.
	LVD contactor has disconnected the battery.	Use <i>DCTools/Web</i> to check LVD is enabled and set to correct values. (LVD status LED on the I/O board is on when contactor is energized.) Check that the I/O board is connected (Power LED is on). Check that the LVD control and power cables are connected. See Connections on page 8 . Check the connections from the battery bus to the LVD.
String Fail Alarm (SC200 only)	The Battery Mid-point Monitoring system has detected a voltage imbalance in one of the battery strings.	See Battery Mid-point Monitoring on page 65 .
	A Battery Mid-point Monitoring sense wire is disconnected.	Check the sense wires.

System Controller Problems

Problem	Possible Cause	Required Action
SC200 or SC100 displays a dc power system alarm message.		See Alarm Descriptions in the System Controller Operation Handbook.
SC200 or SC100 LCD display is blank and green Power On LED is off.	RXP/power cable is disconnected from the SC200 or SC100.	Connect cable from connector YS11 to the dc power system voltage feed module (see Connections on page 8). Wait for start-up to complete.
	The ac supply is off and the batteries are not connected because the Low Voltage Disconnect (LVD) has disconnected.	None. The power system including the SC200 or SC100 will return to normal operation when the ac supply is within its specified voltage range.
	Faulty Voltage Feed Module (VFM) or faulty SC200 or SC100.	Replace faulty unit.
SC200 or SC100 LCD display is blank and green Power On LED is on.	SC200 or SC100 is in start-up mode	Wait for start-up to complete. See Starting the SC200 or SC100 on page 41.
	Faulty SC200 or SC100	Replace faulty SC200 or SC100.
SC200 or SC100 Red LED or Yellow LED is on.	An alarm is active.	Check the type of alarm on the LCD display or with <i>DCTools/Web</i> or <i>PowerManagerII</i> . See Alarm Descriptions in the System Controller Operation Handbook.
Unable to change settings from SC200 or SC100 keypad.	Keypad access is set to <i>Read Only</i> or <i>PIN Protected</i> .	See Keypad Access Security on page 42.
Monitor OK relay (RLY6) is de-energized.	An active alarm, digital input or analog input is mapped to this relay.	Check relay mapping. See Alarms, Analog Inputs, or Digital Inputs in the System Controller Operation Handbook.
	SC200 or SC100 or I/O board software corrupt or hardware fault.	Replace faulty unit.
Incorrect battery or load current readings.	Bus voltage sense polarity is incorrect.	Check the bus voltage sense polarity and correct if necessary.
	Incorrectly configured shunt inputs.	Check shunt mapping and gain is correct.
	Current is within the <i>Battery State Threshold</i> . See details in the System Controller Operation Handbook.	None, normal operation.

Problem	Possible Cause	Required Action
SC200 or SC100 or DCTools/Web displays ??? or N/A	Failed, disconnected or unconfigured sensor.	Replace, connect or configure sensor.
	Faulty or disconnected voltage feed module.	Replace or connect voltage feed module.
	Incorrect I/O board mapping (SC200 only).	Check I/O board mapping. See details in the System Controller Operation Handbook.
SC200 or SC100 displays Config Error	Missing or invalid configuration file.	Either: Load a valid configuration file into the SC200 or SC100. See Backup and Restore on page 40 , or Change one or more configuration settings using the SC200 or SC100 keypad or DCTools.
	Incorrect rectifier voltage, because installed rectifiers have different output voltages.	Check that all rectifiers are of the same type and replace as necessary.
DCTools connection problem (<i>Target Failed to Respond</i> error)	Connection problem	Refer to following communications problems.
USB communications problem (SC200 only)	Incorrect, disconnected or faulty cable.	Check a USB A/B cable is plugged into the USB port and a PC USB port. Replace faulty cable.
	SC200 or SC100 serial communications are disabled.	Check <i>S3P Access</i> is enabled. See details in the System Controller Operation Handbook.
	DCTools not installed on PC or wrong version.	Install latest version of DCTools. Download from www.powerquality.eaton.com/downloads .
	Password required to change settings.	See Write Access Password in the System Controller Operation Handbook.

Problem	Possible Cause	Required Action
Modem/RS232 communications problem.	Incorrect, disconnected or faulty cable.	Check an RS232 straight-thru cable is plugged into XS1 and the modem. Replace faulty cable.
	Access to RS232 connector XS1 is restricted.	Use a DB9 ribbon cable extension (Farnell part number 869-6411).
	Incorrect communications settings.	See PSTN Modem Communications or GSM Modem Communications in the System Controller Operation Handbook.
	Incorrect modem setup string.	Refer to the AT command section in the modem's manual.
	Modem not powered or other modem problem.	Refer to the modem's manual.
	Incompatible modem.	Contact your Eaton dc product supplier or Eaton for advice. See Worldwide Support on page 103 .
	Password required to change settings.	See Write Access Password in the System Controller Operation Handbook.
Serial communications are disabled (SC200 only)	<i>S3P Access</i> is disabled.	<i>Set S3P Access</i> to Enabled. See details in the System Controller Operation Handbook.
Ethernet communications problem (SC200 only)	Incorrect, disconnected or faulty cable.	Check a network patch cable is connected from XS31 to a live network outlet. Replace faulty cable.
	Ethernet link is not active.	On the Ethernet connector (XS31) check: Yellow LED is continuously lit to show link is active. Green LED flashes to show traffic is reaching the SC200. See the diagrams on page 5 for position of the Ethernet connector.
	Incorrect communications settings.	See Ethernet Communications in the System Controller Operation Handbook.
	SC200 serial communications are disabled.	Check <i>S3P Access</i> is enabled. See details in the System Controller Operation Handbook.
	Password required to change settings (using DCTools or PowerManagerII).	See Write Access Password in the System Controller Operation Handbook.

Problem	Possible Cause	Required Action
Web communications problem (SC200 only)	Ethernet communications problem.	See previous entry.
	Cannot connect to web server.	Check IP address and other settings in SC200 are correct. Check correct IP address is used in web browser address bar. See Ethernet Communications in the System Controller Operation Handbook. Check <i>HTTP Access</i> or <i>HTTPS Access</i> is enabled. See Web Access Security in the System Controller Operation Handbook.
	Cannot log on to web server.	Incorrect Logon ID or Password, or no active users setup. Use DCTools to set up an active user. See Web Access Security in the System Controller Operation Handbook.
	Web communications lost (<i>Comms Lost</i> error message).	Check that the SC200 is operating. Check the Ethernet communications connections. See previous entry. Check web browser type and version. See Compatible Software on page 6.
	Lost Logon ID and/or Password.	Use DCTools to set up a new Logon ID and/or Password. See Web Access Security in the System Controller Operation Handbook.
	<i>Default User</i> log on is not available.	<i>Default User</i> is not setup or not active. Use DCTools to set up a <i>Default User</i> . See Web Access Security in the System Controller Operation Handbook.
A user cannot change settings, Backup or Restore, Execute Commands, Upgrade Firmware, or Edit User List.	Check the user's access levels. See Web Access Security in the System Controller Operation Handbook.	
SC200 time/date is incorrect (SC200 only)	Time/date is different on SC200 compared to DCTools/Web.	None. Time shown on SC200 is UTC. Time on PC running DCTools/Web is local time.
	Time needs to be set.	See SC200 Internal Clock in the System Controller Operation Handbook.
	SC200 time can be set, but is incorrect when SC200 restarts.	Internal battery is dead. Return SC200 for service. (If removed, the battery must be disposed of according to the manufacturer's instructions.)

Problem	Possible Cause	Required Action
I/O board Power/Comms OK LED is off	I/O board is not powered or faulty.	Check connection to YH3 on I/O board. See Connections on page 8 . Replace I/O board if faulty.
I/O board Power/Comms OK LED is flashing.	I/O board is responding to an <i>Identify</i> command from the SC200 or SC100.	None, this is normal operation.
LVD Status LED(s) (on I/O board) are on.	LVD contactor is energized.	None, this is normal operation.
LVD Status LED(s) are off (I/O board Power On LED is on).	LVD contactor is de-energized.	None, this is normal operation.
LVD Status LED(s) flashing.	The contactor is in the wrong state (SC200 or SC100 internal state does not match signal from contactor auxiliary switch).	Check the electrical and mechanical operation of the contactor and auxiliary switch. Check all wiring and connectors. See Connections on page 8 .
LVD contactor(s) not operating.	LVD settings incorrect.	Check LVD is enabled and set to correct values. See details in the System Controller Operation Handbook. Check that the LVD manual control is set to AUTO. See details in the System Controller Operation Handbook. Check that the contactor is correctly configured and mapped to the I/O board. See details in the System Controller Operation Handbook (SC200 only).
	Contactor is disconnected.	Check the control and dc power cables are connected. See details on page 8 .

Replacing or Adding a Rectifier

Rectifiers can be replaced without switching off the dc power system and disconnecting the equipment it powers.



- To reduce the risk of electric shock and maintain optimum system cooling, always cover empty rectifier slots with blanking panels.
- To avoid electric shock do not place hands inside the rectifier shelf.
- Do not attempt to disassemble faulty rectifiers. Return them (in their original packaging) with a completed Equipment Incident Report on page [101](#).

Removing a Rectifier

Step 1 - Undo the rectifier retaining screw



This will release the rectifier from its rear connector.

Step 2 - Pull out the rectifier



- The rectifier may be hot, especially after prolonged operation. Use suitable gloves.
- To avoid damage do not rest the rectifier on its connector.

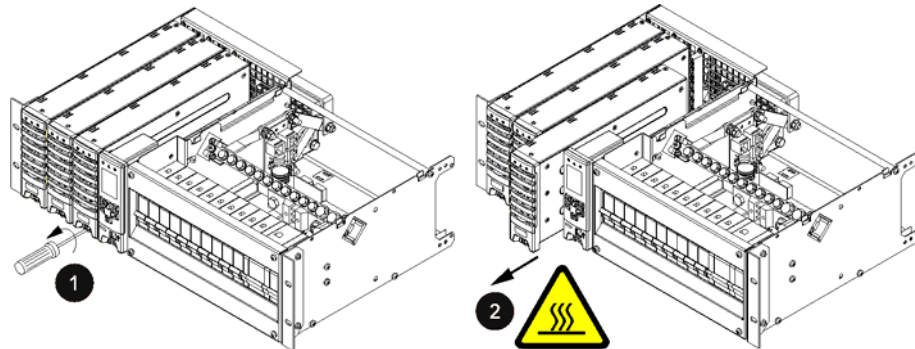

Step 3 - Replace rectifier or fit blank panel



Insert a replacement rectifier into the empty slot (see details in following section), or fit a blank panel.

Procedure complete

Installing a Replacement Rectifier

Step 1 - Remove rectifier blank panel (if fitted)



Step 2 - Align the rectifier with the guides



Step 3 - Push in the rectifier



- 1 Push in the rectifier until the retaining screw contacts the shelf.
- 2 Check the rectifier's rear connector is correctly aligned with the shelf connector, or damage may occur.
- 3 Tighten the retaining screw to 1.5Nm (13.3 inch-pounds). This will locate the rectifier in its rear connector.
- 4 Check that the rectifier's Power On LED turns on (after the startup delay) and the alarm LEDs turn off.



The rectifier will automatically register with the system controller and download its operating parameters. No adjustments are required.

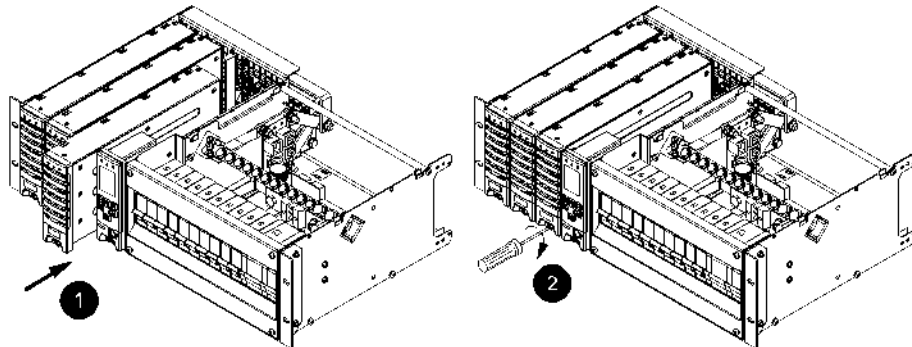

Procedure complete

Replacing or Adding a Load MCB

Step 1 - Remove covers



- 1 Remove the top cover, if fitted.
- 2 Remove the DC Distribution front cover.

Step 2 - Remove existing MCB (if required)



- 1 Disconnect the load cable and the fuse fail detect wire from the MCB top terminal. Insulate the ends of both the cable and the wire.
- 2 Undo the bottom MCB terminal.
- 3 Unclip the MCB from the DIN rail and remove the MCB.

Step 3 - Fit new MCB



- 1 Undo the bottom MCB terminal.
- 2 Insert the new MCB onto the tooth-comb bus and clip onto the DIN rail.
- 3 Tighten the bottom MCB terminal.

Step 4 - Fit a fuse fail detect wire



- 1 Place a spare fuse fail detect wire into the top terminal of the MCB.
- 2 Tighten the top MCB terminal.

Step 5 - Connect load cable (if required)



Follow the procedure on page [26](#).

Step 6 - Replace covers



- 1 Replace the top cover, if fitted.
- 2 Replace the DC Distribution front cover.

Procedure complete

Replacing the System Controller

The SC200 or SC100 system controller can be replaced without switching off the dc power system and disconnecting the equipment it powers.

Before you start you will require:

- A PC/Laptop with *DCTools** connected to the system controller or (SC200 only) a web browser* connected to the system controller via an IP network.
 - *See *Communications Options in the System Controller Operation Handbook*.
- A replacement SC200 or SC100 system controller.
 - A new system controller is factory loaded with a 48V (nominal) default configuration file. *DCTools/Web (SC200 only)* can be used to modify the configuration file already loaded in a system controller. However, a system controller configured for a particular nominal system voltage (48V or 24V) can only be converted to the other nominal system voltage by loading a new configuration file.
- A copy of the appropriate configuration file, either:
 - use the configuration file saved from the existing system controller, or
 - contact your Eaton dc power system supplier to obtain a master configuration file to suit the dc power system. This file will have to be customized for the site.

Step 1 - Backup the configuration file of the old SC200 or SC100 if possible



If the old system controller is still operational use *DCTools/Web* to backup its configuration file.

See *Backup and Restore* on page [40](#).

Step 2 - Remove the system controller



- 1 Undo the system controller retaining screw. See the diagram on page [5](#).
- 2 Partly withdraw the system controller.
- 3 Label then disconnect the cable(s) from the rear connectors.

 *When the system controller stops communicating the rectifier output voltage will be unchanged for 2 minutes. After 2 minutes the rectifier output voltage will change to the Float Voltage and the rectifier yellow LEDs will flash.*

Step 3 - Insert the new system controller

- 1 Connect the cable(s) to the rear connectors.
 *The system controller will start. See Starting the SC200 or SC100 on page [41](#). Various alarms may appear because of incorrect configuration file settings. Press any key to silence the alarm.*
- 2 Insert the system controller and tighten the retaining screw.

Step 4 - Download the configuration file

- 1 Connect to the system controller with *DCTools/Web*. See details on page [44](#) in the System Controller Operation Handbook.
- 2 If a copy of the old configuration file, or a master configuration file is available, then use *DCTools* to restore (download) it to the new system controller.
 *See Backup and Restore on page [40](#) in the System Controller Operation Handbook.*
 *If you receive an error message about the MIB file version, please contact your Eaton dc product supplier for advice.*
- 3 If a copy of the old configuration file, or a master configuration file is not available, then use the keypad or *DCTools/Web* to change the configuration settings to the correct values (provided the system controller is set for the correct nominal system voltage).

Step 5 - Check the system controller operation



- 1 Map the I/O board (SC200 only):
 - In DCTools/Web go to: RXP.
 - Copy the I/O board serial number(s) from the *RXP Devices* table to the *I/O Board to Serial Number Mapping* table to map an *IOB Number* to each I/O board (overwrite an existing serial number if required).
 - If multiple SiteSure-3G modules are connected use the I/O board Identify function to physically identify each module. See details in the System Controller Operation Handbook.*
- 2 Check that the system controller has registered all rectifiers.
- 3 Check all control processes, alarms and current measurement(s).
- 4 Check the power system identification parameters and communications settings.
- 5 Change the configuration file as required to ensure that the system controller operates as intended.
- 6 Check the system controller time (SC200 only). See details in the System Controller Operation Handbook.

Step 6 - LVD Characterization Alarm



If there is no LVD Characterization alarm then ignore this step.

If the SC200 or SC100 indicates an *LVD Characterization Error* alarm then:

- 1 On the SC200 go to: Battery > LVDs > LVD x > Not Characterized > Edit, or on the SC100 go to: Menu > Configuration > LVD1/LVD2
- 2 If available, select *Characterize With IOB Values*. Press *Enter*. No further action is needed.
- 3 If *Characterize With IOB Values* if not available, the LVD must be characterized. This will cause the LVD contactor to disconnect the battery for a few seconds.
 - The load equipment will be powered by the rectifiers.*
 - On the SC200 go to: Battery > LVDs > LVD x > Not Characterized > Edit, or on the SC100 go to: Menu > Configuration > LVD1/LVD2
 - Select *Characterize*. Press *Enter*.
 - The LVD contactor will disconnect and connect. When the characterization is complete the LVD Characterization Error alarm will clear.*

Procedure complete

Return the faulty SC200 or SC100 with a completed Equipment Incident Report on page [101](#).

Replacing the Input/Output Board



- One rectifier must be removed to access the I/O board (unless top access is available).
- If an LVD is fitted the battery will be disconnected when the I/O board is removed (the load equipment will continue to operate from the rectifiers).

Before you start you will require:

- A PC/Laptop with *DCTools** connected to the system controller or (SC200 only) a web browser* connected to the system controller via an IP network.
 - ☐ *See *Communications Options in the System Controller Operation Handbook*.
- A replacement input/output board.
- An anti-static wrist strap to prevent damage to the static sensitive components on the input/output board.

Step 1 - Remove top cover (if fitted)



Step 2 - Remove one rectifier and SC200 or SC100 to access I/O board



- 1 Check that the load current can be supplied by the remaining rectifier(s) when one rectifier is removed.
- 2 Remove the rectifier next to the SC200 or SC100. See Replacing a Rectifier on page [58](#).
 - ☐ Push any key to silence the Rectifier Comms Lost alarm.
- 3 Undo the SC200 or SC100 retaining screw. See the diagram on page [5](#).
- 4 Partly withdraw the SC200 or SC100.
- 5 Label then disconnect the cable(s) from the rear connectors.
 - ☐ The rectifier output voltage will be unchanged for 2 minutes. After 2 minutes the rectifier output voltage will change to the Float Voltage and the rectifier yellow LEDs will flash.

Step 3 - Remove the I/O board



- 1 See the diagram on page [3](#) for location of I/O board.
- 2 Label then disconnect all I/O board cable plugs. Do not disconnect the input/output wires connected to the push-connect terminals (XH15 - XH21).
- 3 Lift the I/O board up and off the support posts and partly remove it from the APS.
- 4 Label then disconnect all the input/output wires connected to the push-connect terminals (XH15 - XH21).
- 5 Place the board in an anti-static bag and return for service. See Equipment Incident Report on page [101](#).



Step 4 - Fit the new I/O board



- 1 Reconnect all the input/output wires to the push-connect terminals (XH15 - XH21).
- 2 Fit the I/O board on to the support posts in the APS.
- 3 Reconnect all I/O board cable plugs.
- 4 Check the I/O board Power On LED is on. If not see Troubleshooting on page [50](#).

Step 5 - Replace rectifier and SC200 or SC100



- 1 Replace the rectifier. See Replacing a Rectifier on page [58](#).
- 2 Connect the cables to the rear SC200 or SC100 connectors.
 *The SC200 or SC100 will start. See Starting the SC200 or SC100 on page [41](#).*
- 3 Insert the SC200 or SC100 and tighten the retaining screw.
- 4 When start-up is complete check that the SC200 or SC100 has registered all rectifiers.
 *Missing Hardware, New Hardware and other alarms will appear because of the I/O board mapping change. Press any key to silence the alarm.*



Step 6 - Update I/O board mapping (SC200 only)



- 1 In DCTools go to: I/O Board > I/O Board to Serial Number Mapping.
- 2 Copy the I/O board serial number from the RXP Bus Slaves table to the I/O Board to Serial Number Mapping table to map an IOB Number to the I/O board (overwrite the existing serial number).
 *The alarms will clear.*

Step 7 - Characterize LVD (if required)



-  *If there is no LVD Characterization Error alarm then ignore this step.*
- If the SC200 or SC100 indicates an LVD Characterization Error alarm then the LVD must be characterized. This will cause the LVD contactor to disconnect the battery for a few seconds.
-  *The load equipment will be powered by the rectifiers.*
- 1 On the SC200 go to: Battery > LVDs > LVD x > Not Characterized > Edit, or on the SC100 go to: Menu > Configuration > LVD1/LVD2
 - 2 Select Characterize. Press Enter.
 *The LVD contactor will disconnect and connect. When the characterization is complete the LVD Characterization Error alarm will clear.*

Procedure complete

Battery Mid-point Monitoring (String Fail) Alarm (SC200 only)

Use the following procedure if a *String Fail* alarm is generated.

Step 1 - Identify the faulty battery string



- 1 Press any button on the SC200 to silence the alarm.
- 2 Connect to the SC200 using DCTools/Web. Go to *Batteries > Mid-point Monitoring*.
- 3 Click + to expand the *Mid-point Monitoring* table to identify which battery string has failed.

Step 2 - Check cell/monobloc voltages



- 1 Use a suitable voltmeter to measure the individual cell/monobloc voltages. Measure on the cable lugs and inter-connecting bars so that loose connections will also be detected.
- 2 The faulty or poorly connected cell/monobloc has the voltage with the greatest deviation from the average.

Step 3 - Check cell/monobloc terminals



- 1 Check the terminal connections of the cell/monobloc are correctly tightened and clean.
 Refer to the battery manufacturer's instructions for correct terminal torque settings.
- 2 In DCTools/Web go to *Batteries > Mid-point Monitoring*. Click *Clear String Fail*.
- 3 If the alarm clears then the fault is fixed. No further action is required.

Step 4 - Service or replace faulty cell/monobloc (if required)



- 1 If the alarm is still present then follow the battery manufacturer's instructions on servicing or replacing the faulty cell/monobloc.
- 2 After the faulty cell/monobloc has been serviced or replaced clear the alarm (see Step 3).

Procedure complete

Battery Disposal and Recycling

Follow Environmental Protection Agency (EPA) guidelines or the equivalent local regulations to dispose of all batteries. Please remember that the owner is responsible and liable to ensure those EPA guidelines or equivalent local regulations are followed.

For assistance contact your local hazardous waste center or Worldwide Support on page [103](#).

Safety Equipment

Use approved safety equipment as required by local health and safety regulations including (but not restricted to):

- Safety glasses
- Safety gloves
- Safety footwear
- Appropriate handling equipment for batteries and other heavy items
- Appropriate platform(s) and access for working at height (if required)

Essential Tools

Standard electrical toolkit with insulated tools, plus:

- Cable crimping tool and crimp lugs suitable for all cable sizes and connectors used
- Torque wrench with pivot head and insulated handle
- Heatshrink tubing and heat gun
- Digital multimeter
- Insulation tester
- Non-static clothing

Recommended Tools

- Laptop with:
 - USB port (for use with SC200) or RS232 port (for use with SC100)
 - DCTools software (download from www.powerquality.eaton.com/downloads).
- Test load (to suit maximum output of dc power system)
- Labeling tool and labels
- Clamp-on ammeter

Spare Parts

Item	Description	Part Number
1	Rectifier. See replacement procedure on page 58 .	48V, 2000W: Eaton APR48-ES 48V, 1800W: Eaton APR48-3G 48V, 900W: Eaton EPR48-3G 24V, 1440W: Eaton APR24-3G
2	Rectifier blank panel (to cover un-used rectifier positions)	Eaton RMB-08
3	System controller. See replacement procedure on page 60 .	Eaton SC100-00 or SC200-00
4	Input/Output Board. See replacement procedure on page 63 .	Eaton IOBGP-00
5	Optional top cover	Eaton 621-08919-30
6	USB A/B cable for use with SC200 system controller	RadioShack 55010997, Jaycar WC7700, or equivalent.
7	RS232 DB9 F/F Null-modem cable - for use with SC100 system controller	RadioShack 55010600, Jaycar WC7513, or equivalent. (Cross-over connections: 5-5, 2-3, 3-2)
8	SiteSure-3G Input/Output Module (optional) (SC200 only)	Eaton IOBSS-00. See details on page 31 .
9	Dual temperature sensors (2m leads)	Eaton TS2-200
10	Battery Mid-point Monitoring connection kit for use with SC200 (for two battery strings)	Eaton MPTLOOM-3300 (2 x 3m sense wires), or Eaton MPTLOOM-7600 (1 x 7m, 1 x 6m sense wires)

Standard Torque Settings

Use the following torque settings unless specific values are stated on the fastener or elsewhere.

For battery terminals use the torque values specified by the battery manufacturer.

Thread Size ISO Coarse	Minimum - Maximum Torque
M2.5	0.3 - 0.4Nm (2.7 - 3.5 inch-pounds)
M3	0.5 - 0.6Nm (4.5 - 5.3 inch-pounds)
M4	1.1 - 1.3Nm (9.8 - 11.5 inch-pounds)
M5	2.3 - 2.7Nm (20.5 - 23.9 inch-pounds)
M6	3.9 - 4.5Nm (35 - 39 inch-pounds)
M8	9.5 - 11.1Nm (85 - 98 inch-pounds)
M10	18.7 - 21.9Nm (166 - 194 inch-pounds)
M12	32.8 - 38.4Nm (292 - 340 inch-pounds)
M16	81.5 - 95.1Nm (724 - 844 inch-pounds)

Notes:

- 1 Torque settings are for mild steel, brass and stainless steel.
- 2 Torque is based on 60% of yield stress of the material. Yield for the purposes of this chart is 240MPa.
- 3 Tolerance range is 60 - 70 % of yield.
- 4 When a bolt and nut is torqued use a spanner to prevent rotation.

System Input

Input Voltage <i>Refer to the rectifier specifications for range.</i>	220-240V (nominal L-N) 208V (nominal L-L)
Maximum Input Current (per phase @ V = 175V)	1P+N+PE (220-240V nom.): 36A 2P+PE (208V nom.): 36A 3P+N+PE (220-240V nom.): 12A 3P+PE (208V nom.): 21A
Frequency Range	45-66Hz
Maximum Earth Leakage Current	1.3mA per rectifier

System Output

Output Voltage (nominal)	24V / 48V (dependent on rectifier model)
Output Power (maximum)	24V: APR24-3G rectifiers: 4.32kW 48V: EPR48-3G rectifiers: 2.7kW APR48-3G rectifiers: 5.4kW APR48-ES rectifiers: 6.0kW
Output Voltage Range	21.5 - 29V / 43 - 57.5V

Rectifiers

Operating Ranges	
APR24-3G/APR48-3G/EPR48-3G:	Rated: 175 - 275V Full output up to 50°C [122°F] Extended: 90 - 300V Reduced output power below 175V
APR48-ES:	Rated: 185 - 275V Full output up to 50°C [122°F] Extended: 90 - 300V Reduced output power below 185V
Input Current (maximum) <i>175V ac, 20°C [68°F]</i>	APR24-3G: 9.5A EPR48-3G: 5.7A APR48-3G: 12A APR48-ES: 12A
Rated Output Power	APR24-3G: 1440W EPR48-3G: 900W APR48-3G: 1800W APR48-ES: 2000W
Rated Output Current	APR24-3G: 50A @ 28.8V EPR48-3G: 18.75A @ 48V APR48-3G: 37.5A @ 48V APR48-ES: 41.7A @ 48V
Preset Voltage	APR24-3G: 27V ± 0.1V Other models: 54.5V ± 0.1V
Rectifier Input Fuses (internal)	EPR48-3G: 8A, 250V Other models: 16A, 250V

Environment

Ambient Temperature Range (<i>operating</i>)	-40°C to 70°C [-40°F to 158°F] <i>Output derates above 50°C and below -10°C [14°F].</i>
Relative Humidity (<i>operating and storage</i>)	<95% (non condensing)

Dimensions H, W, D

APS3-300	3U, 19" mounting, 306 mm [12"]*
----------	---------------------------------

* Additional clear air space is required at rear for rectifier exhaust air venting. See details on page [25](#).

Weight

APS3-300	6kg [13 lb]*
Access Power Rectifier (APR24-3G, APR48-3G)	1.7kg [3.7 lb]

* weight of a typical configuration, excluding rectifiers

Digital Outputs/Alarm Relays (IOBGP)

Number of Digital Outputs/Relays	6 (one also used for Monitor OK alarm)
Contact Arrangement	One changeover contact per relay
Contact Rating	0.1A @ 60V dc maximum
Connectors	Screwless terminal blocks
Wire Size	0.5 - 2.0mm ² [20 - 14 AWG]
Isolation	Relay connections are isolated to 500V dc from all other circuitry, earth and system common.

Digital Inputs (IOBGP)

Number of Digital Inputs	6
Connectors	Screwless terminal blocks
Wire Size	0.5 - 2.0mm ² [20 - 14 AWG]
Input Types	Voltage-free switch or relay contacts only
Input Range	Live Bus to Live Bus + 5V
Input Common	Same bus as used for current shunts (Live bus is standard)
Input Protection	Protected against damage from short circuit to live or common bus

Temperature Sense Inputs (IOBGP)

Number of Temperature Sense Inputs	2 <i>One only connected as standard. Second input available (requires additional temperature sensor).</i>
Range	2.53V to 3.43V (-20 to +70°C [-4 to +158°F])
Resolution	< 0.01V (< 1°C [1.8°F])
Accuracy	±1°C [1.8°F] at 25°C [77°F], ±2°C [3.6°F] over rated temperature range
Maximum Cable Length	20m (65 feet)
Connector	RJ45

Current Sense Inputs (IOBGP)

Number of Current Sense Inputs	3 (one used for internal current shunt)
Range	-50 to +50mV
Resolution	<50µV
Accuracy	±0.5% at 25°C [77°F], ±1% over rated temperature range
Connector	RJ45

Battery Mid-point Monitoring (SC200 only)

Number of Strings	Standard: 4 Maximum: 24 (with additional IOBGP-01 I/O boards)
Range	-35V to +35V
Resolution	<30mV
Accuracy	±0.5% at 25°C [77°F], ±1% over rated temperature range

Low Voltage Disconnect (IOBGP)

Number of contactor connections	2
Contactor Type	SC100 systems: Normally Open (NO) or Normally Closed (NC), with or without auxiliary contacts SC200 systems: Normally Open (NO) with auxiliary contacts only
Contactor Coil Voltage (nominal)	With auxiliary contacts: 12V, 24V or 48V Without auxiliary contacts: Equal to nominal system voltage
Maximum Hold-in Current	1.2A (per contactor)
Connector	MTA156 (4-way)

Communications

USB (SC200 only)	Version:	1.1 (12Mbits/s)
	Connector:	USB B (female)
RS232	Interface:	RS232 (DTE)
	Connector:	DB9M
Ethernet (SC200 only)	Interface:	10baseT
	Connector:	RJ45
	Protocols:	TCP/IP, SNMP, S3P over IP, http (Web), https (secure Web), SNTP, Modbus-TCP, Serial Server
	MAC Address:	See details in the System Controller Operation Handbook.
	Web browser:	Microsoft Internet Explorer 8 (IE6 is compatible but with reduced performance), Mozilla Firefox 3.0.
External modem options	Type:	PSTN or GSM
	Operation:	Dial in/Dial out on alarm*

* Can operate as a backup for Ethernet communications (SC200 only).

SC200 Menu



At each menu screen press *Enter* to access the associated configuration menu screen(s).

 These menus have multiple configuration menu screens. See details in the System Controller Operation Handbook.

SC100 Menu

The following diagram shows the Status Screens and main navigation.

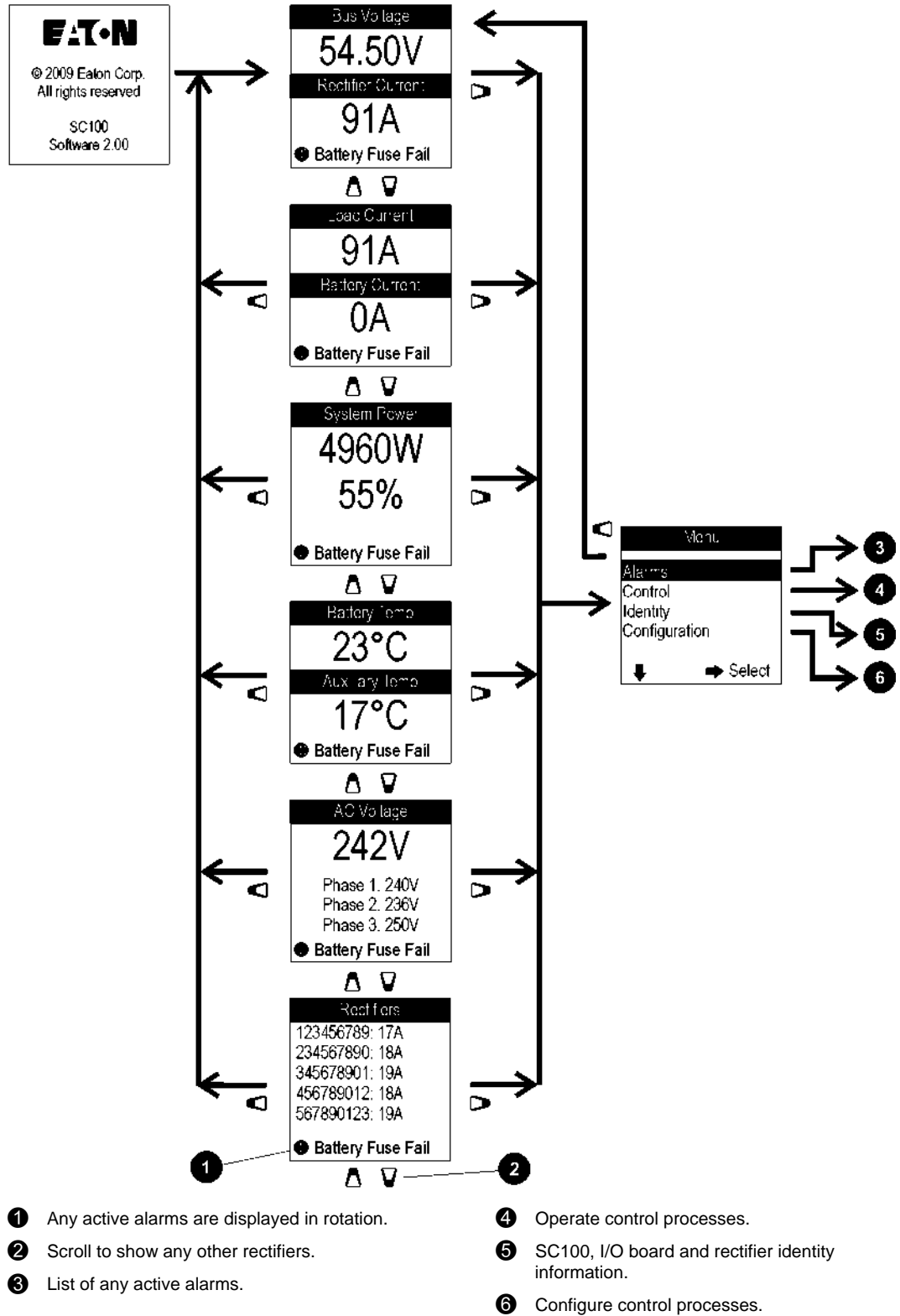

Connector Pin-outs

System Controller Connector Pin-outs

Connector	Type	Purpose	Pin	Description
XS1	DB9M	RS232 Serial Interface	1	-
			2	RD (Receive Data)
			3	TD (Transmit Data)
			4	DTR (Data Terminal Ready)
			5	Common (Ground)
			6	-
			7	RTS (Request to Send)
			8	-
			9	-
XS31 (SC200 only)	RJ45	Ethernet Interface	1	Rx
			2	Rx
			3	Tx
			4	-
			5	-
			6	Tx
			7	-
			8	-
YS11	RJ45	RXP System Communications	1	+24/48V (System bus voltage)
			2	+24/48V (System bus voltage)
			3	-
			4	RS485-A
			5	RS485-B
			6	-
			7	0V
			8	0V
USB (SC200 only)	USB B	USB Serial Interface	1	VCC (+5 V dc)
			2	Data -
			3	Data +
			4	Ground

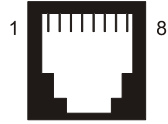
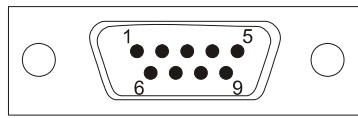

RS232 D9M and RJ45 connector pin-outs

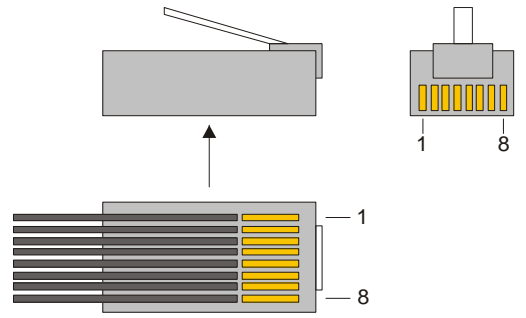

RJ45 plug pin-outs

I/O Board (IOBGP-00, -01) Connector Pin-outsSee input and output specifications on page [71](#).

Connector	Type	Purpose	Pin	Description
XH4	MTA 156	LVD1 Interface	1	Coil -
			2	Coil +
			3	LVD1 auxiliary switch
			4	Auxiliary switch common
XH5	MTA 156	LVD2 Interface	1	Coil -
			2	Coil +
			3	LVD2 auxiliary switch
			4	Auxiliary switch common
XH6	RJ45	Current Sense Inputs	1	Current Input 1 Common
			2	Current Input 1
			3	+12V out
			4	Current Input 2 Common
			5	Current Input 2
			6	0V out
			7	Current Input 3 Common
			8	Current Input 3
XH7	RJ45	Temperature Sense Inputs	1	-
			2	-
			3	-
			4	Temp Sense 1+
			5	Temp Sense 1-
			6	-
			7	Temp Sense 2+
			8	Temp Sense 2-
XH8	MTA 156	LVD Power	1	Bus live
			2	Common
XH9	MTA 156	Bus Voltage Sense Input See Specifications.	1	Controller reference (Live)
			2	Controller sense (Com)
XH12A	MTA 156	Battery Mid-point Monitoring sense inputs (SC200 only)	1	String 1 Mid-point
			2	String 2 Mid-point
			3	String 3 Mid-point
			4	String 4 Mid-point
XH15A		Digital inputs D1-D3	1	D1 input
			2	0V

Connector	Type	Purpose	Pin	Description
			3	D2 input
			4	0V
			5	D3 input
			6	0V
XH15B		Digital inputs D4-D6	1	D4 input
			2	0V
			3	D5 input
			4	0V
			5	D6 input
			6	0V
XH16/XH17		Digital relay outputs 1-2	1	Relay 1 normally closed (NC)
			2	Relay 1 normally open (NO)
			3	Relay 1 Common (COM)
			4	Relay 2 normally closed (NC)
			5	Relay 2 normally open (NO)
			6	Relay 2 Common (COM)
XH18/XH19		Digital relay outputs 3-4	1	Relay 3 normally closed (NC)
			2	Relay 3 normally open (NO)
			3	Relay 3 Common (COM)
			4	Relay 4 normally closed (NC)
			5	Relay 4 normally open (NO)
			6	Relay 4 Common (COM)
XH20/XH21		Digital relay outputs 5-6	1	Relay 5 normally closed (NC)
			2	Relay 5 normally open (NO)
			3	Relay 5 Common (COM)
			4	Relay 6 normally closed (NC)
			5	Relay 6 normally open (NO)
			6	Relay 6 Common (COM)
YH3	RJ45	DC power system digital inputs	1	Load Fuse Fail
			2	Battery Fuse Fail
			3	+12V out
			4	AC Distribution Fan Fail
			5	AC Distribution MOV Fail
			6	0V out (system live - protected)
			7	-
			8	System common - protected

Connector	Type	Purpose	Pin	Description
YH11	RJ45	RXP System Communications	1	+24/48V (System bus voltage)
			2	+24/48V (System bus voltage)
			3	-
			4	RS485-A
			5	RS485-B
			6	-
			7	0V
			8	0V

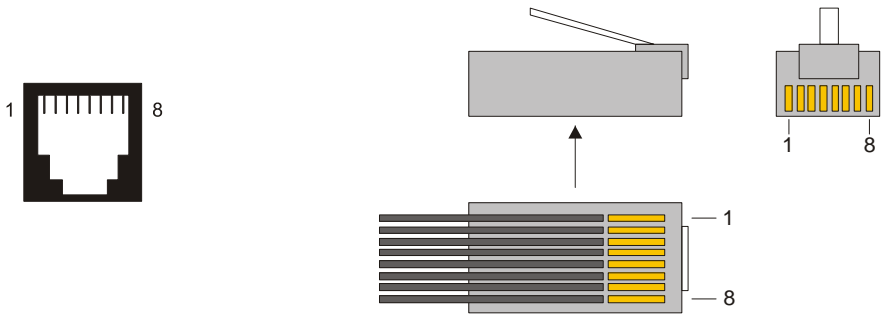

RJ45 connector pin-outs

RJ45 plug pin-outs

Transient Protection

To prevent damage to Eaton Access Power Solutions from lightning and transient over-voltages, structural lightning protection and transient protection must be installed at each site.

Transient protection will also protect against other sources of transients, such as:

- Circuit or grid switching by the power company
- Electrical switching of large inductive loads (such as motors, transformers, and electrical drives) or capacitive loads (such as power factor correction) or manufacturing equipment.

Use a suitably qualified consultant to develop a transient protection plan (compliant with IEC 61643-12) for the equipment to be installed at the site. The transient protection plan and associated installation must:

- 1 Capture the lightning strike at a known and preferred point outside the building
- 2 Conduct the main lightning energy safely to earth
- 3 Dissipate the lightning energy into a low impedance earthing system
- 4 Eliminate earth potential differences inside the building
- 5 Protect the ac supply using a coordinated transient voltage surge suppression plan, that includes:
 - Primary surge protection
 - Secondary surge protection
 - Primary / secondary surge decoupling coils
 - Secondary / tertiary surge decoupling coils
- 6 Protect the data and control lines using a coordinated transient voltage surge suppression plan

Earthing (Grounding)

The most important aspect of any power system installation at a site is the integrity of the earthing systems. Effective earthing will significantly increase site protection. Most sites have a number of earthing systems such as:

- AC Power earth
- DC Power earth
- Tower / building lightning protection earth

For optimum protection, all earths must be brought together at one "star" point. Otherwise, surge currents can flow within the system creating large voltages. These can cause damage to equipment that does not normally require surge protection, such as rectifier outputs and communications interfaces.

If there is a tower on the site then use the tower earth as the "star" point. This is because it conducts the majority of the surge to earth, especially if the site is lightning-prone. For other sites, a 'direct-lightning' earth will not be available therefore a structural or power system earth will be used. In multi-floor buildings, always try to use structural earths if the common earth point cannot be found at ground level. For basements / single floor buildings, the ac supply earth is usually the most appropriate.

Primary Transient Protection

Primary transient protection must be considered at all sites. Eaton recommends, primary transient protection on the incoming ac supply either at the main ac switchboard or sub-switchboard.

In the absence of sufficient information, primary transient protective devices with a minimum repeat strike rating of 100kA (8/20 μ s wave shape) are recommended.

In addition, primary transient protection must be coordinated with downstream secondary transient protection via suitably rated surge decoupling coils. These should have been specified as part of the transient protection plan for the site. If no surge decoupling coils were specified, then air-core 15 μ H surge decoupling coils are suitable.

Secondary Transient Protection

Secondary transient protection (downstream from the primary transient protection) must be present at all sites to protect the dc power system from transients.

Some models of Access Power Solutions are factory-fitted with secondary transient protection to protect the power system from a limited number of repeated 15kA transients (8/20 μ s wave shape).

Factory-fitted secondary transient protection typically consist of:

- Phase-to-neutral metal oxide varistors (MOVs) with a voltage rating of 440V, capable of withstanding temporary over-voltages
- A neutral-to-earth spark gap (gas discharge tube)
- Surge decoupling coils

If secondary transient protection is not fitted inside the Access Power Solutions, then external secondary transient protection must be installed in the ac switchboard that supplies the dc power system.

Carefully consider the residual voltage seen by the dc power system (maximum 6kV) and the decoupling between the transient protection system and the dc power system. Transients must be limited to less than 2kA.

Tertiary Transient Protection

Eaton rectifiers are fitted with 6kV/3kA transient protection. This is designed to protect the rectifiers from voltage spikes generated during operation of the upstream transient protection system. Do not install rectifiers without adequate upstream surge protection.

Installation

Install the transient protection according to the following diagram.

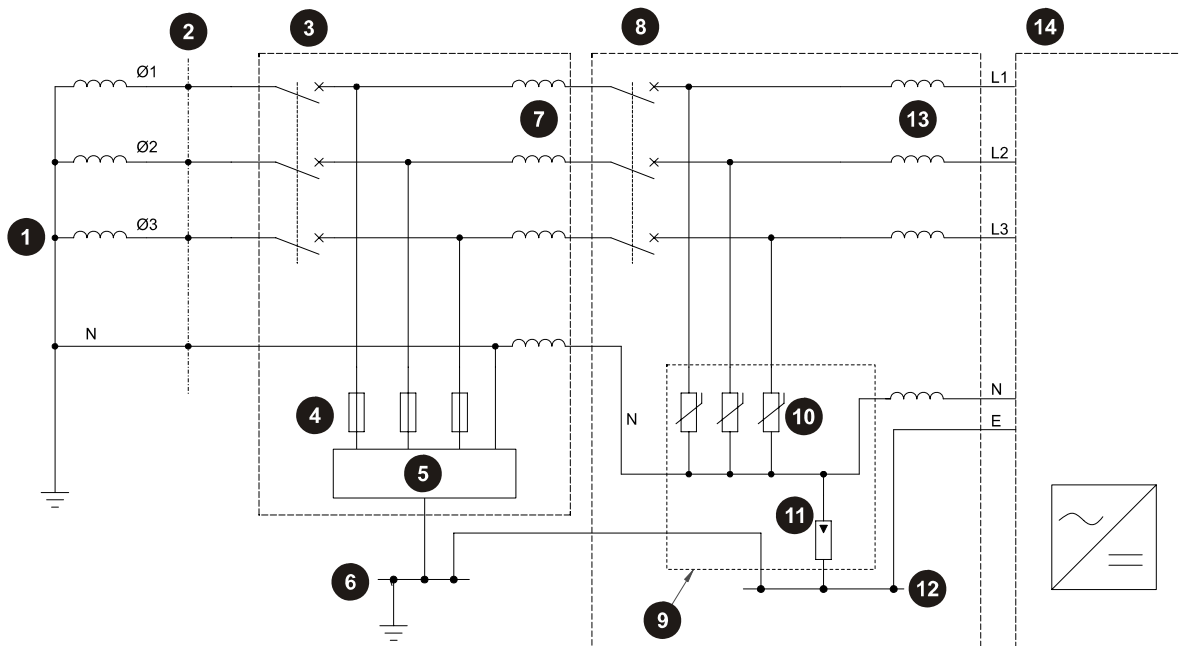

- | | | |
|---|--|--|
| ① Supply transformer | ⑦ Primary/secondary surge decoupling coils (4, refer to text for rating) | ⑪ Spark gap (neutral-earth) |
| ② Building entrance | ⑧ AC sub-switchboard or APS dc power system | ⑫ Switchboard earth/ground busbar |
| ③ Main switchboard | ⑨ Secondary transient protection | ⑬ Secondary/Tertiary surge decoupling coils (4 x 11µH minimum) |
| ④ Fuses | ⑩ MOVs (3, phase-neutral, refer to text for rating) | ⑭ Access Power Rectifiers |
| ⑤ Primary transient protection (refer to text for rating) | | |
| ⑥ Building earth/ground busbar | | |

Transient protective devices are fitted with alarm contacts and visual indicators. Monitor the status of all externally installed transient protective devices. Either:

- Regularly inspect the visual indicators
- Connect the alarm contacts to the MOV Fail termination on the I/O board (preferred option) or to the building management system. See the Connections diagram on page 8 for location of MOV Fail termination (YH3) and connector pin-outs on page 79.

 *The alarm signal lines of the external transient protective devices must be isolated from the ac supply (by voltage-free relay contacts) before connecting these signal lines to the APS dc power system.*

The earthing arrangement of your communications equipment determines how the dc common bus of the dc power system is referenced to earth.

There are two options: ac and dc earths bonded, or ac and dc earths separated.

AC-dc Earth Linked (recommended)

During a lightning surge, very large voltages can develop between ac earth and dc common bus as the surge current flows through the earth cables to earth.

Access Power Solutions dc power systems are factory fitted with an ac-dc earth link (see the diagrams on page 22). This link prevents these very large voltages from developing and protects the rectifiers from surge related damage.

If your installation uses a mesh earth, then Eaton recommends that this factory fitted ac-dc earth link is retained. No further action is then required

However, if your policy is not to bond the ac and communications earth (no mesh earth), then refer to the following instructions to isolate the ac and dc earths.

AC and DC Earth Isolated

Perform the following steps to isolate the ac and dc earths, and (if required) install a transient protective device.

Step 1 - Disconnect dc common bar from ac earth



- 1 Remove the ac-dc earth link screw.
- 2 Undo the screws securing the dc common bar to the plastic stand-offs.
- 3 Undo the bolt connecting the common bar to the common bus and remove the bar.
- 4 Use the earth link screw (without the flat washer) to re-attach the stand-off to the chassis.
- 5 Refit the common bar. Tighten the bolt and screws according to the Standard Torque Settings on page 68.

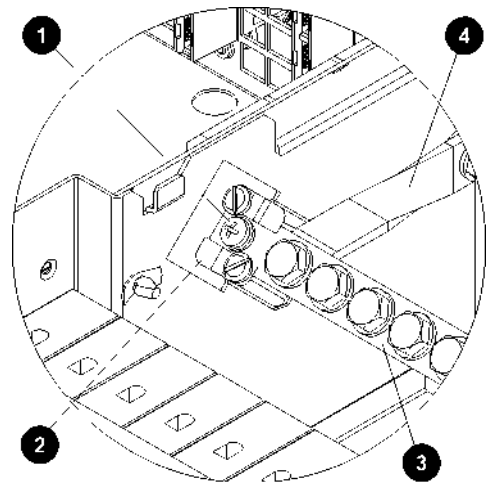

- 1 ac-dc earth link screw
- 2 Stand-off
- 3 dc common bar
- 4 Common bus

Step 2 - Remove or replace the ac-dc Earth Link



Ignore this Step if the factory fitted ac-dc earth link is used.

There are two options if the ac-dc earth link cannot be retained. Either:

- If the site surge protection is designed to limit transient ac earth - dc earth voltages to less than 1500V at the dc power system, then remove the ac-dc earth link as in Step 1. No further action is required..

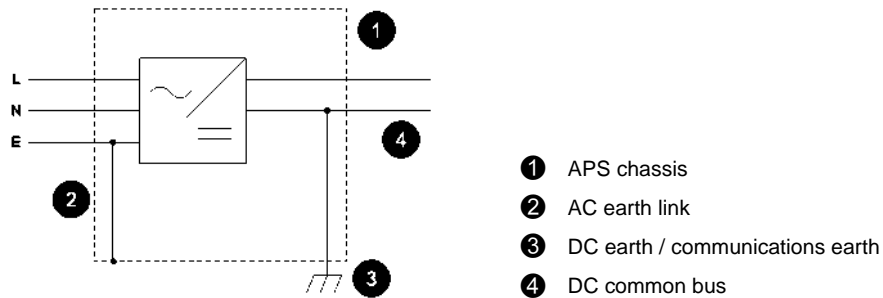

- Or, if the site surge protection is not designed to limit transient ac earth - dc earth voltages to less than 1500V at the dc power system, then replace the ac-dc earth link with a surge protection device.

The surge protection device bonds the ac and communications earths during transient activity to prevent damage to the rectifiers. The preferred surge protection device is a transient earth clamp (TEC).

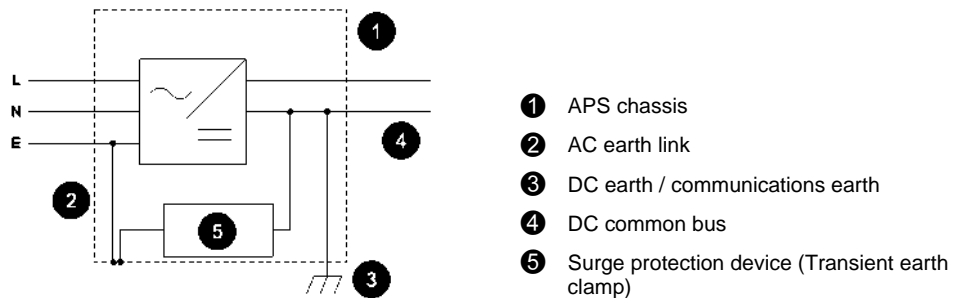

The path between ac earth and dc common bus (via the surge protection device) must be as short and straight as possible, preferably less than 500mm (20").

The transient earth clamp must have the following minimum specifications.

- Nom. dc Spark-over Voltage 600V
- Impulse Spark-over Voltage at 1 kV/μs < 1400V
- Nom. Impulse Discharge Current – 8/20μs wave shape 20kA
- Insulation Resistance at 100V ≥ 10¹⁰ Ω
- Capacitance < 1.5pF

A larger transient earth clamp with a high kA rating must be used if the potential severity of a lightning strike is high.

Procedure complete

Commissioning

 Complete the tasks in this appendix only if a formal commissioning test is required.

Before starting these Commissioning tasks:

- Complete all the Installation tasks (see details on page [16](#))
- Complete all the Start-Up tasks (see details on page [34](#))
- Save a copy of the configuration file.

Complete the Commissioning tasks in the following order:

 During the testing, note any changes to the configuration file that are incorrect.

Task	Description	Reference
1	Analog Inputs	See details on page 90
2	System Controls	See details on page 92
3	System Alarms	See details on page 96
4	Digital Inputs	See details on page 99
5	Digital Outputs (Relays)	See details on page 100

Analog Inputs

Equipment required:

- Digital Voltmeter
- DC Load bank
- DC Current Clamp meter
- Trim pot adjustment tool
- Thermometer

Test	Test procedure	Adjustment
DC Voltage	<ul style="list-style-type: none"> • Measure the dc voltage across the dc bus. • Ensure the bus voltage on the SC200 or SC100 display and in DCTools/Web is within specifications. 	None
Battery Current (High current test) Note 1	<ul style="list-style-type: none"> • Conduct the load test and turn off the rectifiers. • Measure the load current with a dc clamp meter. • Ensure the current displayed on the SC200 or SC100 and in DCTools/Web is within specification. • Ensure the current is the correct polarity. 	Adjust the gain setting on the current sensor by moving the trim pot. Adjust the gain setting in the SC200 or SC100
Load Current (High current test) Note 2	<ul style="list-style-type: none"> • Connect a load bank to the dc load connection • Apply a high load to the system • Measure the load current with a dc clamp meter • Ensure the load current displayed on the SC200 or SC100 and in DCTools/Web is within specification. • Ensure the current is the correct polarity. 	Adjust the gain setting on the current sensor by moving the trim pot. Adjust the gain setting in DCTools/Web.
Total System Current (High current test)	<ul style="list-style-type: none"> • Repeat the load test. • Ensure the system current displayed on the SC200 or SC100 and in DCTools/Web is within specification. 	None
Load Current (No current test)	<ul style="list-style-type: none"> • Disconnect the load bank from the system. • Ensure the load current displayed on the SC200 or SC100 and in DCTools/Web is 0 amps. 	Adjust the current offset setting of the SC200 or SC100.
Battery Current (No current test)	<ul style="list-style-type: none"> • Disconnect the load bank from the system. • Ensure the battery current displayed on the SC200 or SC100 and in DCTools/Web is 0 amps. 	Adjust the current offset setting of the SC200 or SC100.
Total System Current (No current test)	<ul style="list-style-type: none"> • Disconnect the load bank from the system. • Ensure the total system current displayed on the SC200 or SC100 and in DCTools/Web is 0 amps. 	None
Temperature	<ul style="list-style-type: none"> • With thermometer, measure the temperature at the power system temperature sensor. • Ensure the temperature input displayed on the SC200 or SC100 and in DCTools/Web is within specification. • Test each temperature input. 	Some temperature sensors have an adjustable trim pot.
User assigned Analog Inputs Note 3	<ul style="list-style-type: none"> • Test the accuracy and alarm mapping for all analog inputs. • Check the name, severity and alarm thresholds are correct. 	See Note 3.

Notes

- 1** When the rectifiers are turned off, the battery current will supply all the current to the load. At this time the battery current will equal the load current.
This test assumes there is a current sensor on the dc Load Bus. If batteries are not installed on the system, connect the load bank to the battery bus.
If the battery current is determined by a summation, conduct the load current test before the battery current test.
- 2** The test should be done at the maximum expected system load current.
This test assumes there is a current sensor on the dc load bus.
- 3** As the analog inputs can be configured for many different types of analog signal, tests have not been detailed on this test sheet.
User assigned analog inputs are not available on all systems.

System Controls

Equipment Required:

- DC Load bank

Test	Test procedure	Adjustment
Voltage Control Note 1	<ul style="list-style-type: none"> • Apply a load to the power system. • With <i>DCTools</i>, ensure the bus voltage matches the <i>Target Voltage</i> as shown on the Voltage Control Summary of <i>DCTools</i>. 	None
Temperature Compensation Note 2	<ul style="list-style-type: none"> • Heat the battery temperature sensor. • Ensure the system voltage changes in accordance with the configured slope. 	None
Equalize	<ul style="list-style-type: none"> • Set the <i>Equalize Duration</i> to 1 minute. • Start an <i>Equalize</i>. • Ensure the system voltage increases to the <i>Equalize Voltage</i>. • Ensure the SC200 or SC100 indicates an <i>Equalize</i> has started. • Ensure the <i>Equalize</i> stops after the 1 minute duration. • Return the <i>Equalize</i> duration to the original setting. 	None
Fast Charge Note 3	<ul style="list-style-type: none"> • Set the <i>Fast Charge Max Duration</i> to 1 minute. • Set the <i>Fast Charge Voltage Threshold</i> to a value approximately 1V below the system float voltage. • Connect load to the system. • Turn off the ac to the system. • Allow the system voltage to fall below the <i>Fast Charge Voltage Threshold</i>. • Turn on the ac. • Ensure the system performs a <i>Fast Charge</i>. • Ensure the SC200 or SC100 indicates a <i>Fast Charge</i> has started. • Ensure the <i>Fast Charge Voltage</i> is correct. • Ensure the <i>Fast Charge</i> stops after 1 minute. • Return the <i>Fast Charge</i> settings to the original values. 	None
Generator Control Option (SC200 only) Note 4	<ul style="list-style-type: none"> • Set the <i>Voltage Threshold</i> to a value approximately 1V below the system float voltage. • Connect load to the system. • Turn off the ac to the system. • Allow the system voltage to fall below the <i>Voltage Threshold</i>. • Ensure the system performs a <i>Fast Charge</i>. • Ensure the SC200 indicates a <i>Generator Enable</i>. • Ensure the <i>Generator Enable</i> digital output activates. • Turn on the ac. • Ensure the <i>Generator Enable</i> stops after 1 minute. • Return the settings to the original values. 	None
Battery Current Limit Note 5	<ul style="list-style-type: none"> • Reduce the <i>Battery Current Limit</i> setting to 5%. • Connect load to the system. • Turn off the ac to the system. • Allow the battery to discharge for a period. • Turn on the ac. 	None

Test	Test procedure	Adjustment
	<ul style="list-style-type: none"> Monitor the battery current to ensure the <i>Battery Current Limit</i> control process is operating. 	
Current Share Note 6	<ul style="list-style-type: none"> View the individual rectifier currents with the SC200 or SC100 or DCTools/Web. Ensure the currents are all at 0 amps. Connect load to the system. Ensure that all rectifiers share the load evenly and any variation is within specification. 	None
Battery Test	<ul style="list-style-type: none"> Set the <i>Battery Test Interval</i> to 0 days. Set the <i>Battery Test Duration</i> to 30 minutes Set the <i>Battery Test Termination Voltage</i> to a value approximately 2 volts below the float voltage. Connect load to the system. Start the <i>Battery Test</i>. Ensure the SC200 or SC100 indicates that a <i>Battery Test</i> has started. Wait until the system voltage reduces below the <i>Termination Voltage</i>. Confirm the <i>Battery Test</i> fails. Ensure the <i>Battery Test Fail</i> alarm is displayed on the SC200 or SC100. Ensure the <i>Battery Test</i> stops and the system voltage returns to the float voltage setting. Clear the <i>Battery Test Fail</i> alarm in DCTools/Web. Set the <i>Battery Test Duration</i> to 1 minute. Set the <i>Battery Test Termination Voltage</i> to a value approximately 10 volts below the float voltage. Connect load to the system. Start the <i>Battery Test</i>. Ensure the SC200 or SC100 indicates that a <i>Battery Test</i> has started. Wait for the <i>Battery Test Duration</i> time to expire. Confirm the <i>Battery Test</i> passes. Ensure the <i>Battery Test</i> stops and the system voltage returns to the float voltage setting. Reset the <i>Battery Test</i> settings to the original values. 	None
Low Voltage Disconnect – Manual Operation Note 7	<ul style="list-style-type: none"> Set the LVD manual control to <i>CONNECT</i>. Ensure the LVD contactor is connected. Ensure the SC200 or SC100 displays an <i>LVD Manual</i> alarm. Ensure the I/O board LVD LED is on. Set the LVD manual control to <i>AUTO</i>. Ensure the SC200 or SC100 shows no LVD alarms. Ensure the I/O board LVD LED is on. Set the LVD manual control to <i>DISCONNECT</i>. Ensure the LVD contactor disconnects. Ensure the SC200 or SC100 displays an <i>LVD Manual</i> 	None

Test	Test procedure	Adjustment
	alarm. <ul style="list-style-type: none"> • Ensure the I/O board LVD LED is off. • Set the LVD manual control to <i>AUTO</i>. • Ensure the LVD connects. • Ensure the SC200 or SC100 shows no LVD alarms. • Ensure the I/O board LVD LED is on. 	
Low Voltage Disconnect – Automatic Operation Note 7	<ul style="list-style-type: none"> • Check the LVD contactor is connected. • Increase the <i>LVD Disconnect Voltage Threshold</i>. • Reduce the system voltage below the <i>LVD Disconnect Voltage Threshold</i>. • Wait for the configured <i>Recognition Period</i>. • Ensure the LVD disconnects. • Ensure the SC200 or SC100 displays an <i>LVD Disconnected</i> alarm • Ensure the I/O board LVD LED is off. • Increase the system voltage above the configured <i>Reconnect Voltage</i>. • Wait for the configured <i>Recognition Period</i>. • Ensure the LVD connects. • Ensure the SC200 or SC100 shows no LVD alarms. • Ensure the I/O board LVD LED is on. 	None
Low Voltage Disconnect – Alarms Note 7	<ul style="list-style-type: none"> • Disconnect each LVD control cable from the I/O board. • Ensure the SC200 or SC100 displays an <i>LVD Fail</i> alarm. • Ensure the I/O board LVD LED is flashing. • Reconnect the cables. • Ensure the LVD connects. • Ensure the SC200 or SC100 shows no LVD alarms. • Ensure the I/O board LVD LED is on. 	None

Notes

- 1** AVC must be enabled. Allow up to 1 minute for the system to stabilize after load or voltage changes.
- 2** Breathing on the sensor can increase the temperature.
- 3** Battery Current Limit control process may have to be turned off to allow the Fast Charge voltage to reach its value within the 1 minute test duration.
- 4** For details see Generator Control Option in the System Controller Operation Handbook.
- 5** There may be slight current fluctuations above and below the configured current limit setting. This can be due to the current control within the factory preset deadband. Confirmation of this control process may be witnessed in the Fast Charge test.
- 6** There may be a delay of up to 2 minutes before the currents stabilize between rectifiers.
- 7** There may be a delay of up to 10 seconds before the LVD changes state.
APS systems may not display a Manual Connect alarm on the SC200 or SC100 if the system voltage is above the LVD disconnect voltage.
Perform the test on each LVD control module within the system.
For manual LVD operation see details in the System Controller Operation Handbook.
For an explanation of LVD LED indications see Troubleshooting on page [50](#).

System Alarms

Equipment Required:

- dc load bank
- dc power supply

Test	Test procedure	Adjustment
General notes about alarm testing	<ul style="list-style-type: none"> • For all alarms check the following where applicable: <ul style="list-style-type: none"> • SC200 or SC100 LED status. • SC200 or SC100 display indication. • DCTools/Web alarm indication • Remote alarm indication (PowerManagerII, SNMP traps, etc) • Digital outputs (relays). • Reducing the alarm recognition time will reduce the alarm testing time. • There may be more than 1 method to perform the following alarm tests. 	
Low Float Note 1	<ul style="list-style-type: none"> • Increase the <i>Low Float Threshold</i> to just below the float voltage. • Reduce the system voltage by heating the battery temperature sensor - or - • Disconnect the battery from the system. • Start a <i>Battery Test</i>. • The system voltage will fall. • Ensure alarm operates. 	
Low Load	<ul style="list-style-type: none"> • Test as for the <i>Low Float</i> test. Note that the <i>Low Load Threshold</i> is lower than the <i>Low Float threshold</i>. • Ensure alarm operates. 	
High Float Note 1	<ul style="list-style-type: none"> • Set the system <i>Float Voltage</i> above the <i>High Float Threshold</i>. - or - • Reduce the <i>High Float Threshold</i> and increase the system voltage by starting an <i>Equalize</i>. - or - • Reduce the <i>High Float Threshold</i> and increase the system voltage by cooling the battery temperature sensor. • Ensure alarm operates. 	
High Load	<ul style="list-style-type: none"> • Increase the system voltage. • Test as for the High Float test. ☐ Note the <i>High Load Threshold</i> is higher than the <i>High Float Threshold</i> • Ensure alarm operates. 	
Rectifier Fail	<ul style="list-style-type: none"> • Turn off a rectifier ac MCB (if fitted). • The rectifier will turn off. • Ensure alarm operates. 	
Multiple rectifier fail	<ul style="list-style-type: none"> • Turn off the ac MCBs to 2 rectifiers (if fitted). • The rectifiers will turn off. • Ensure alarm operates. 	
Rectifier comms	<ul style="list-style-type: none"> • Remove a rectifier from the system. 	

Test	Test procedure	Adjustment
lost	<ul style="list-style-type: none"> • Ensure alarm operates. 	
Multiple Rectifier comms lost	<ul style="list-style-type: none"> • Remove 2 rectifiers from the system. • Ensure alarm operates. 	
Partial AC Fail	<ul style="list-style-type: none"> • Turn off the ac to more than 20% of the rectifiers in the system. • Ensure alarm operates. 	
AC Fail	<ul style="list-style-type: none"> • Turn off all ac to the system. • Ensure alarm operates. 	
System Overload	<ul style="list-style-type: none"> • Reduce the <i>System Overload Recognition Period</i> to 0 minutes. • Apply load to the system. • Turn off rectifiers until the <i>System Overload Threshold</i> is exceeded. • Ensure alarm operates. 	
Load Fuse Fail Note 2	<ul style="list-style-type: none"> • Apply load to the system. • Turn off the MCB feeding the load bank. • Ensure alarm operates. 	
Battery Fuse Fail	<ul style="list-style-type: none"> • Turn off a Battery MCB or remove a Battery Fuse. • Ensure alarm operates. 	
Battery Test Fail	<ul style="list-style-type: none"> • See Battery Test in the System Controller Operation Handbook for details. 	
MOV Fail	<ul style="list-style-type: none"> • Remove a MOV cartridge from the MOV housing (if fitted). • Ensure alarm operates. 	
ACD Fan Fail	<ul style="list-style-type: none"> • Stop the ACD Fan (if fitted). • Ensure alarm operates. 	
LVD alarms	<ul style="list-style-type: none"> • See LVD test on page 92 for details. 	
Battery Temperature Low	<ul style="list-style-type: none"> • Increase the <i>Battery Temperature Low Threshold</i> above the current temperature. - or - • Cool the temperature sensor until the threshold is exceeded. • Ensure alarm operates. 	
Battery Temperature High	<ul style="list-style-type: none"> • Reduce the <i>Battery Temperature High Threshold</i> below the current temperature. - or - • Heat the battery temperature sensor until the threshold is exceeded. • Ensure alarm operates. 	
Sensor Fail	<ul style="list-style-type: none"> • Disconnect the battery temperature sensor from the I/O board (XH7). • Ensure alarm operates. • Replace the battery temperature sensor. • Disconnect the current sensor (XH6). • Ensure alarm operates. • Replace the current sensor. • Disconnect the voltage sensor (XH9). 	

Test	Test procedure	Adjustment
	<ul style="list-style-type: none"> • Ensure alarm operates. • Replace the voltage sensor. 	
Equalize	<ul style="list-style-type: none"> • For details see Equalize test in System Controls on page 92. 	
Fast Charge	<ul style="list-style-type: none"> • For details see Fast Charge test in System Controls on page 92. 	
Battery Test	<ul style="list-style-type: none"> • For details see Battery Test in System Controls on page 92. 	
In Discharge Note 3	<ul style="list-style-type: none"> • Connect load to the system. • Turn off the ac supply to the rectifiers. • Allow the battery to start discharging. • Ensure alarm operates. 	
Config Error Note 4	<ul style="list-style-type: none"> • Load incorrect configuration file. - or - • Remove all rectifiers from the system. • Apply an incorrect external voltage to the system: <ul style="list-style-type: none"> • 24V for a 48V system • 48V for a 24V system • Ensure alarm operates. 	
User Assigned Alarms	<ul style="list-style-type: none"> • See User Digital Input test on page 99. 	
Battery Current Limit	<ul style="list-style-type: none"> • For details see Battery Current Limit test in System Controls on page 92. 	
Rectifier No Load	<ul style="list-style-type: none"> • Ensure the dc load and batteries are isolated from the system. • Ensure alarm operates. 	
Rectifier Current Limit	<ul style="list-style-type: none"> • Apply a dc load to the system. • Turn off rectifiers until the remaining rectifiers reach the <i>Rectifier Current Limit</i> threshold. - or - • Set the <i>Rectifier Current Limit</i> slightly below the existing rectifier current being delivered to the load. • Ensure alarm operates. 	
High Rectifier Temperature Note 5	<ul style="list-style-type: none"> • Unable to test. 	
AC Phase 1/2/3 Fail Note 6	<ul style="list-style-type: none"> • Turn off ac phase 1 to the power system. • Ensure alarm operates. • Repeat for phase 2 and phase 3. 	
AC Phase 1/2/3 Voltage Note 6	<ul style="list-style-type: none"> • Reduce the <i>High AC Threshold</i> below the existing ac voltage. • Ensure alarm operates. • Increase the <i>Low AC Threshold</i> above the existing ac voltage. • Ensure alarm operates. 	
AC Frequency Note 6	<ul style="list-style-type: none"> • Change the Nominal AC Frequency setting. • Change the AC Frequency Threshold. • Ensure alarm operates. 	

Test	Test procedure	Adjustment
Engine Run Option Note 7	<ul style="list-style-type: none"> Change the state of the digital input with <i>Engine Run</i> function. Ensure alarm operates. 	

Notes

- 1 Ensure Alarm Tracking is disabled. Ensure Temperature Compensation is enabled.
- 2 If the load is not connected to the load MCBs and if an electronic Fuse Fail detect circuits is installed, this test can also be performed as follows:
 - Turn off the load MCB
 - Connect a high impedance path >100kΩ) between the end load side of the MCB and the Common Bus. (The impedance path can also be created by touching these points with your hand.)
- 3 Ensure the battery discharge is high enough. Allow for the recognition time.
- 4 This alarm will be displayed if the incorrect configuration or incorrect rectifiers are used in the system. It is not recommended that this be tested as it is very unlikely for an incorrect configuration to be installed after commissioning.
- 5 This alarm is originated from the rectifier. It can only be tested by increasing the internal temperature of the rectifier.
- 6 These alarms are only available with the external ac metering option.
- 7 A digital input must be configured for this test to function. See details in the System Controller Operation Handbook.

Digital Inputs

Test	Test procedure	Adjustment
Digital Input 1	<ul style="list-style-type: none"> Change the state of the Digital input. Ensure any alarms mapped to the digital output (relay) activate. Ensure the Digital Input Alarm Name is correct. 	
Digital Input 2	As for Digital Input 1.	
Digital Input 3	As for Digital Input 1.	
Digital Input 4	As for Digital Input 1.	
Digital Input 5	As for Digital Input 1.	
Digital Input 6	As for Digital Input 1.	
User Assigned Digital Inputs Note 1	<ul style="list-style-type: none"> As for Digital Input 1. Check the severity and digital output (relay) mapping is correct. 	

Notes

- 1 As the Digital Inputs can be configured for many different digital input devices, specific tests have not been detailed on this test sheet.

Digital Outputs (Relays)

Test	Test procedure	Adjustment
Digital Output 1 Note 1	<ul style="list-style-type: none"> Set the <i>Test State</i> to <i>Relay Active</i> or <i>Relay Inactive</i>. Ensure the digital output changes state and any remote alarms are extended. Wait for the <i>Relay Test Duration</i> time. Ensure the digital output state and any extended alarms return to their original state. 	
Digital Output 2	As for Digital Output 1.	
Digital Output 3	As for Digital Output 1.	
Digital Output 4	As for Digital Output 1.	
Digital Output 5	As for Digital Output 1.	
Digital Output 6 Note 2	As for Digital Output 1.	
User assigned Digital Outputs	As for Digital Output 1.	

Notes

- Digital Outputs can also be checked as other system tests are performed.
- This digital output is typically configured as the *Monitor OK* relay. Test extended alarms by removing the power to the I/O board. This will de-energize the relay.

Commissioning Completed

Restore the original (backed-up prior to the testing) configuration file.

Use DCTools/Web to change any configuration file settings that were noted as incorrect during the Commissioning tests.

EQUIPMENT INCIDENT REPORT

Please enter as much information as you can. Send the completed form, together with the item for repair to your nearest authorized service agent. NOTE: Only one fault to be recorded per form.
For further information contact your local Eaton dc product supplier or Eaton (see contact details on page 103). Or email: CustomerServiceNZ@eaton.com

Date: _____

Customer Information

Company: _____

Postal Address: _____

Return Address: _____
(Not PO Box)

Telephone: _____ Fax: _____ Email: _____

Contact Name: _____

Location of Failure

Product code: _____ Serial number: _____ Document number: _____

System type installed in: _____ Serial number: _____

Site name or location: _____

Fault discovered Delivery Unpacking Installation
 Initial test Operation after ____ years Other _____

Failure source Design Manufacturing Documentation
 Transportation Installation Handling

Effect on system operation None Minor Major _____

INFORMATION (fault details, circumstances, consequences, actions)

Internal use only.

Reference No: _____ RMA: _____ NCR: _____ Signature: _____ Date: _____

For product information and a complete listing of worldwide sales offices, visit Eaton's website at: www.eaton.com/telecompower or email: DCinfo@eaton.com

For technical support contact either your local Eaton dc product representative, the closest office from the following list, telephone **(+64) 3 343-7448**, or email CustomerServiceNZ@eaton.com

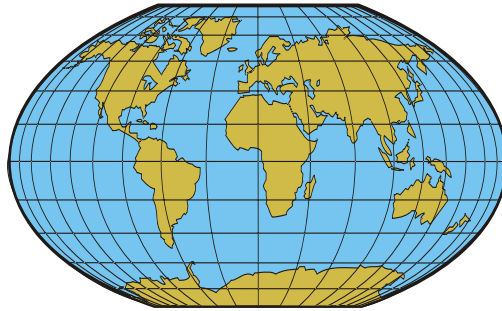

Australia	1300 877 359
Canada	1-800-461-9166
Central America	+52 55 9000 5252
China	+86-571-8848-0166
Europe / Middle East / Africa	+44-1243-810-500
Hong Kong / Korea / Japan	+852-2745-6682
India	+91-11-4223-2325
New Zealand	0800 DC Power (327-693)
Singapore / South East Asia	+65 6825 1668
South America	+54-11-4124-4000
South Pacific	+64-3-343-7448
Taiwan	+886-2-6600-6688 or free call 0800-038-168
United States of America (Toll Free)	1-800-843-9433

?

??? on SC200 or SC100 Display • 43, 54

A

AC Earth

AC-DC Earth Connection • 19, 87

Connection Point • 3

Site Earth • 16

AC phase/neutral terminals • 3

AC Supply

AC Discrimination • 16

AC MCB • 22

AC Rating Label • 2, 22

AC Supply Cord (pre-fitted) • 3

AC Terminal Cover • 3

Connection to AC Supply • 22, 31, 35

Earth Leakage Current • 16, 71

High AC Voltage Protection • 16

Specifications • 71

Startup • 35

Transient Voltage Protection • 16, 83

Tripping Curve • See AC Discrimination

Alarms

Audible Alarm Indication • 43

LEDs (SC200 or SC100) • 43, 53

LVD Status LED • 6, 57

Monitor OK Alarm • 6, 53

Rectifier Alarms • 4, 35

Rectifier LEDs • 4

Relays • See Digital Outputs (Relays)

SC200 or SC100 Alarms • 35, 43, 53

Sound • See Audible Alarm Indication

APR-3G Series Rectifiers • See Rectifiers

Audible Alarm Indication • 43

B

Battery

Battery Charging • 37

Battery Current • 53

Battery Fuses • 52

Battery Installation • 27

Disposal and Recycling • 65

Mid-Point Monitoring (MPM) • 10, 27, 73

Reverse Polarity • 37

String Fail Alarm • 52, 65

Temperature Sensor • 6, 8, 28, 73

Battery Circuit Breakers • 52

Connecting to MCBs • 26

Fitting MCBs • 19

Location • 2

Blank Panel • See Spares

Browsers (recommended) • 6

Bus Voltage

Bus Voltage Sense • 6

C

Characterization of LVD • 62, 63

Circuit Breakers

Connecting to MCBs • 26

Fitting MCBs • 19

Location • 2

Replacing or Adding a Load MCB • 59

Clearances • 25

Commissioning • 89

Communications • 5, 74

Browsers (recommended) • 6

Communications Options • 9

Connector • 5, 8

DCTools • 6, 9, 44, 45, 67

Ethernet Communications • 9, 55

GSM Modem Communications • 9, 55

Problems • See Troubleshooting

PSTN Modem Communications • 9, 55

SNMP • 9

USB Communications • 44, 54

Web Access Security • 56

Web Server • 9, 56

Write Access Password • 55

Configuration File • 36, 40, 60

Backup and Restore • 40

Connection to AC Supply • 22, 31, 35

Current

Battery Current • 53

Load Current • 53
Rectifier Current • 41
Current Sense • 6, 8, 73

D

Damage (transport) • 14, 34
DC Common
 AC-DC Earth Connection • 19, 87
 Location • 2
 Polarity • 19
DC Distribution Cover • 2
DCTools • 6, 9, 44, 45, 67
 N/A (in DCTools/Web) • 54
 Software Versions • 6
 Target Failed to Respond Error • 54
 Write Access Password • 55
Digital Inputs • 72
 Connectors • 6, 8, 79
Digital Outputs (Relays) • 9, 72
 Connectors • 6, 8, 79
Discrimination • See AC Discrimination

E

Earth
 AC-DC Earth Connection • 19, 87
 Earth Leakage Current • 16, 71
 Positive/Negative Earth Operation • See Polarity
 Site Earth • 16
EMC Compliance • 14
Ethernet
 Connector • 5, 8
 Ethernet Communications • 9, 55
 Problems • See Troubleshooting

F

Fuse
 Battery Fuses • 52
 Rectifier Fuses • See AC Discrimination

G

GSM Modem Communications • 9, 55

H

High AC Voltage Protection • 16

I

Identity Information • 46
Input/Output (I/O) Board
 Connections to other system components • 8
 Connector Pin-outs • 79
 Description • 6, 8
 Digital Inputs • 72
 I/O Board Mapping • 60, 63
 Input/Output Cabling • 29
 Location • 3
 LVD Status LED • 6, 57
 Power On LED • 6, 57, 63
 Repair and Return • 101
 Replacing the Input/Output Board • 63
Internal Clock • 56

K

Keypad
 Keypad Access Security • 42, 53

L

LCD Display • 42, 53
LEDs
 LEDs (SC200 or SC100) • 43, 53
 LVD Status LED • 6, 57
 Power On LED • 6, 57, 63
 Rectifier LEDs • 4
 Troubleshooting • 50
Lightning Protection • See Transient Voltage Protection
Load Circuit Breakers
 Connecting to MCBs • 26
 Fitting MCBs • 19
 Location • 2
 Replacing or Adding a Load MCB • 59
Load Current • 53
Low Voltage Disconnect (LVD) • 9
 Characterization of LVD • 62, 63
 Connectors • 6, 8, 79
 Location • 3
 LVD Alarms • See Troubleshooting

LVD Status LED • 6, 57
Problems • 57
LVD • See Low Voltage Disconnect (LVD)

M

Main Screen • 41
Mid-Point Monitoring (MPM) • 10, 27, 73
 String Fail Alarm • 52, 65
Modem (PSTN, GSM) • See Communications
Monitor OK Alarm • 6, 53
MOVs • See Transient Voltage Protection
 MOV Fail Alarm • 83
MPM • See Mid-Point Monitoring (MPM)

N

N/A (in DCTools/Web) • 54
Network Management System (NMS) • See
 SNMP

O

Output Voltage and Current • 71

P

Parts • See Spares
Password
 Web Access Security • 56
 Write Access Password • 55
PC/Laptop (Connection via USB) • See USB
 Communications
Polarity • 19
 Reverse Polarity • 37
Power
 System Power • 71
PowerManagerII • 6
Problems • See Troubleshooting
Protection
 Transient Voltage Protection • 16, 83
PSTN Modem Communications • 9, 55

R

Rack Mounting Brackets • 19, 25
Rectifiers • 71
 Blank Panel • See Spares
 Description • 4

Earth Leakage Current • 16, 71
Inserting the Rectifiers • 34
Location • 2
Output Voltage and Current • 71
Problems • See Troubleshooting
Rectifier Alarms • 4, 35
Rectifier blank panel • 58
Rectifier Current • 41
Rectifier Fuses • See AC Discrimination
Rectifier LEDs • 4
Rectifier Replacement • 58
Registration • 35
Repair and Return • 101
Startup • 35
System Power • 71
Relays • See Digital Outputs (Relays)
 Monitor OK Alarm • 6, 53
Repair and Return • 101
Residual Current Devices (RCD) • 16
Reverse Polarity • 37
RS232 • 45
 Connector • 5, 8
 Modem (PSTN, GSM) • See Communications
 Null-modem RS232 Cable • 67, 68

S

Safety Equipment • See Tools
SC200 or SC100 system controller
 ??? on SC200 or SC100 Display • 43, 54
 Configuration File • 36, 40, 60
 Connections to other system components • 8
 Connector Pin-outs • 77, 79
 Description • 5
 Identity Information • 46
 Internal Clock • 56
 Keypad • 42, 53
 LEDs (SC200 or SC100) • 43, 53
 Location • 2
 Main Screen • 41
 N/A (in DCTools/Web) • 54
 Problems • See Troubleshooting
 Repair and Return • 101
 Replacing the System Controller • 60
 SC200 or SC100 Alarms • 35, 43, 53
 Security • See Keypad Access Security

Startup • 41
Security
 Keypad Access Security • 42, 53
 Web Access Security • 56
 Write Access Password • 55
Servicing • 14, 101, 103
SiteSure-3G I/O module
 Connection to APS • 2, 31
SMS Text Messaging • See GSM Modem Communications
SNMP • 9
SNTP • See Internal Clock
Software Versions • 6
Sound • See Audible Alarm Indication
Spares • 68
Specifications • 71
String Fail Alarm • 52, 65
System Power • 71

T

Target Failed to Respond Error • 54
Technical Assistance • 103
Temperature • 72
 Temperature Sensor • 6, 8, 28, 73
Text Messaging (SMS) • See GSM Modem Communications
Time • See Internal Clock
Tools • 67
Top Cover • 2
Torque Settings • 68
Transient Voltage Protection • 16, 83
 MOV Fail Alarm • 83
Troubleshooting • 50
 Damage (transport) • 14, 34
 Repair and Return • 101
 Servicing • 14, 101, 103
 Technical Assistance • 103

U

USB
 Connector • 5, 8
 Problems • See Troubleshooting
 USB Cable • 44, 68
 USB Communications • 44, 54

V

Voltage (Bus) • See Bus Voltage Sense
Voltage Control
 Bus Voltage Sense • 6
Voltage Feed Module • 2, 8

W

Web
 Browsers (recommended) • 6
 Web Access Security • 56
 Web Server • 9, 56
Write Access Password • 55