

# Eaton UPS Accessories

System Parallel Module  
Installation and Operation Manual



*Powering Business Worldwide*



---

## **IMPORTANT SAFETY INSTRUCTIONS SAVE THESE INSTRUCTIONS**

---

This manual contains important instructions that you should follow during installation and maintenance of the SPM. Please read all instructions before operating the equipment and save this manual for future reference.

---

**©2014 Eaton Corporation**  
**All Rights Reserved**

The contents of this manual are the copyright of the publisher and may not be reproduced (even extracts) unless permission granted. Every care has been taken to ensure the accuracy of the information contained in this manual, but no liability can be accepted for any errors or omission. The right to make design modifications is reserved.

# Table of Contents

<b>1</b>	<b>INTRODUCTION</b>	<b>1</b>
1.1	Installation Features	1
1.2	Model Configurations	2
1.3	Using This Manual	2
1.4	Conventions Used in This Manual	2
1.5	Symbols, Controls, and Indicators	3
1.6	For More Information	3
1.7	Getting Help	3
<b>2</b>	<b>SAFETY WARNINGS</b>	<b>4</b>
<b>3</b>	<b>INSTALLATION PLAN AND UNPACKING</b>	<b>5</b>
3.1	Creating an Installation Plan	5
3.2	Preparing the Site	5
3.2.1	Environmental and Installation Considerations	6
3.2.2	SPM Wiring Preparation	9
3.3	Inspecting and Unpacking the SPM	11
3.4	Breaker Location	12
<b>4</b>	<b>INSTALLATION</b>	<b>13</b>
4.1	Preliminary Installation Information	13
4.2	Unloading the SPM Cabinet from the Pallet	13
4.3	External Power Cables Connecting	15
4.4	External Signaling Cables Connecting	15
4.5	Initial Startup	18
4.6	Completing the Installation Checklist	18
<b>5</b>	<b>ONELINES AND SCHEMATICS</b>	<b>20</b>
5.1	Schematics	20
<b>6</b>	<b>MAINTENANCE</b>	<b>21</b>
6.1	Important Safety Instructions	21
6.2	Performing Preventive Maintenance	21
6.2.1	DAILY Maintenance	21
6.2.2	PERIODIC Maintenance	21
6.2.3	ANNUAL Maintenance	21
6.2.4	BATTERY Maintenance	21
6.3	Maintenance Training	21
<b>7</b>	<b>PRODUCT SPECIFICATIONS</b>	<b>22</b>
7.1	Specifications	22
7.1.1	Electrical Specifications	22
7.1.2	Environmental Specifications	22

**List of Figures**

Figure 1-1. Eaton System Parallel Module ..... 1

Figure 1-2. Eaton System Parallel Module and UPS(93E as example). .... 2

Figure 3-1. SPM Cabinet Dimensions(Front, Right and Rear Views) ..... 7

Figure 3-2. SPM Cabinet Dimensions (Top and Bottom Views). .... 7

Figure 3-3. SPM Cabinet as Shipped on Pallet (wood container removed) ..... 12

Figure 3-4. Breaker Location ..... 12

Figure 4-1. Removing the Front Shipping Bracket. .... 14

Figure 4-2. Attaching the Ramp to the Pallet ..... 14

Figure 4-3. Removing the Rear Shipping Bracket ..... 14

Figure 4-4. Rolling the Cabinet Down the Ramp. .... 14

Figure 4-5. Power Terminal Locations ..... 16

Figure 4-6. Power and Signal Terminal Locations ..... 17

Figure 5-1. SPM Schematics ..... 20

**List of Tables**

Table 3-1. SPM Cabinet Weights ..... 6  
Table 3-2. SPM Cabinet Clearances ..... 6  
Table 3-3. External Power Wiring Requirements for EBCB ..... 9

## Chapter 1 Introduction

The Eaton® System Parallel Module (SPM) provides means to isolate each parallel connected UPS module output (for UPS module maintenance) and bypass switchgear to isolate the complete system for maintenance.

The SPM is housed in a single free-standing cabinet with safety shields behind the doors for hazardous voltage protection. The cabinets match the UPS cabinet in style and color.

Figure 1-1 shows the SPM.



### NOTE

Startup and operational checks must be performed by an authorized Eaton Customer Service Engineer, or the warranty terms specified become void. This service is offered as part of the sales contract for the SPM. Contact an Eaton service representative in advance (usually a two-week notice is required) to reserve a preferred startup date.

---

## 1.1 Installation Features

Power wiring can be routed to the bottom/ rear or top of the cabinet with connections to UPS easily. Control/ signaling wiring is routed through the sides or top of the cabinet and must be installed in accordance with Class 1 wiring methods.

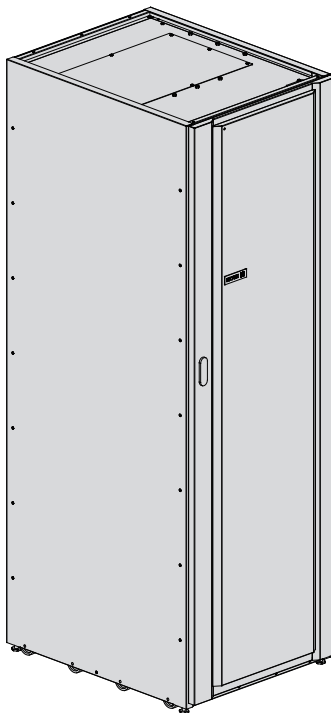

**Figure 1-1. Eaton System Parallel Module**

Line-up-and-match SPM cabinets are installed adjacent to the UPS. The recommended installation location is on the right side of the UPS cabinet.

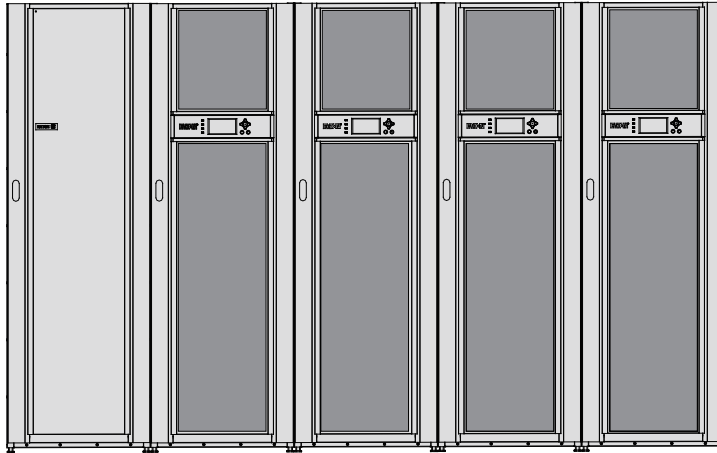

Figure 1-2. Eaton System Parallel Module and UPS(93E as example)

## 1.2 Model Configurations

The following model configurations are available.

- 360kVA to allow 4 x 120kVA UPS systems in a 3+1 system.
- 240kVA to allow 3x 120kVA UPS systems in a 2+1 system
- 120kVA to allow 2x 120kVA UPS systems in a 1+1 system
- 600kVA to allow 4 x 200kVA UPS systems in a 3+1 system.
- 400kVA to allow 3x 200kVA UPS systems in a 2+1 system
- 200kVA to allow 2x 200kVA UPS systems in a 1+1 system

## 1.3 Using This Manual

This manual describes how to install the SPM and is divided into chapters. Read and understand the procedures described to ensure trouble-free installation and operation.

Read through each procedure before beginning the procedure. Perform only those procedures that apply to the SPM being installed or operated.

## 1.4 Conventions Used in This Manual

This manual uses these type conventions:

- Bold type highlights important concepts in discussions, key terms in procedures, and menu options, or represents a command or option that you type or enter at a prompt.
- Italic type highlights notes and new terms where they are defined.
- Screen type represents information that appears on the screen or LCD.

Icon	Description
<b>Note</b>	Information notes call attention to important features or instructions.
[Keys]	Brackets are used when referring to a specific key, such as [Enter] or [Ctrl].



In this manual, the term UPS refers only to the UPS cabinet and its internal elements. The term UPS system refers to the entire power protection system – the UPS cabinet, SPM system, and options or accessories installed.

The term line-up-and-match refers to accessory cabinets that are physically located adjacent to the UPS. The term standalone refers to accessory cabinets that are located separate from the UPS.

## 1.5 Symbols, Controls, and Indicators

The following are examples of symbols used on the UPS or accessories to alert you to important information:



RISK OF ELECTRIC SHOCK - Observe the warning associated with the risk of electric shock symbol.



CAUTION: REFER TO OPERATOR'S MANUAL - Refer to your operator's manual for additional information, such as important operating and maintenance instructions.



This symbol indicates that you should not discard the UPS or the UPS batteries in the trash. This product contains sealed, lead-acid batteries and must be disposed of properly. For more information, contact your local recycling/reuse or hazardous waste centre.



This symbol indicates that you should not discard waste electrical or electronic equipment (WEEE) in the trash. For proper disposal, contact your local recycling/reuse or hazardous waste centre.

## 1.6 For More Information

Refer to the Eaton 93E UPS (80-200 kVA, 380/400/415V) Installation and Operation Manual or 93PM UPS (50-200kW, 380/400/415V) Installation and Operation Manual for the following additional information:

- UPS, optional components, and accessory installation instructions, including site preparation, planning for installation, and wiring and safety information. Detailed illustrations of cabinets and optional accessories with dimensional and connection point drawings are provided.
- UPS operation, including UPS controls, functions of the UPS, standard features and optional accessories, procedures for starting and stopping the UPS, and information about maintenance and responding to system events.
- Communication capabilities of the UPS system.

## 1.7 Getting Help

If help is needed with any of the following:

- Scheduling initial startup
- Regional locations and telephone numbers
- A question about any of the information in this manual
- A question this manual does not answer

Please call your local service representative.

## Chapter 2 Safety Warnings

---

### IMPORTANT SAFETY INSTRUCTIONS SAVE THESE INSTRUCTIONS

---

This manual contains important instructions that should be followed during installation and maintenance of the SPM. Read all instructions before operating the equipment and save this manual for future reference.

---

The SPM are designed for industrial or computer room applications with UPS, and contains safety shields behind the door and front panels. However, any installation and operations should be handled with appropriate care.

---

#### DANGER

---

The Accessories may contain LETHAL VOLTAGES. All repairs and service should be performed by AUTHORISED SERVICE PERSONNEL ONLY.

---

#### WARNING

---

- The terminals may carry live voltage even when the Accessory is connected to UPS.
  - To reduce the risk of fire or electric shock, install the SPM in a temperature and humidity controlled, indoor environment, free of conductive contaminants. Ambient temperature must not exceed 40°C (104°F). Do not operate near water or excessive humidity (95% maximum).
  - As a result of the connected loads high leakage current is possible. Connection to earth ground is required for safety and proper product operation. Do not check Accessory or UPS operation by any action that includes removal of the earth (ground) connection with loads attached.
  - Ensure all power is disconnected before performing installation or service.
  - ELECTRIC ENERGY HAZARD. Do not attempt to alter any Accessory, UPS or battery wiring or connectors. Attempting to alter wiring can cause injury.
- 

#### CAUTION

---

- Installation or service should be performed by qualified service personnel knowledgeable of SPM and required precautions. Keep unauthorized personnel away from equipment. Consider all warnings, cautions, and notes before installing or servicing equipment. DO NOT DISCONNECT the batteries while the UPS is in Battery mode.
  - See installation instructions before connecting to the supply.
  - Determine if the battery is inadvertently grounded. If it is, remove the source of the ground.
  - Contacting any part of a grounded battery can cause a risk of electric shock. An electric shock is less likely if you disconnect the grounding connection before you work on the batteries.
  - Keep the SPM cabinet doors closed and front panels installed to protect personnel from dangerous voltages inside the unit.
  - The operating environment should be maintained within the parameters stated in this manual.
  - Keep surroundings uncluttered, clean, and free from excess moisture.
  - Observe all DANGER, CAUTION, and WARNING notices affixed to the inside and outside of the equipment.
-

## Chapter 3 Installation Plan and Unpacking

Use the following basic sequence of steps to install the System Parallel Module

1. Create an installation plan.
2. Prepare your site for the SPM.
3. Inspect and unpack the SPM.
4. Unload and install the SPM, and wire the system.
5. Complete the Installation Checklist.
6. Have authorized service personnel perform preliminary operational checks and start up the system.



### NOTE

Startup and operational checks for parallel systems or installations with accessory cabinets must be performed by an authorized Eaton Customer Service Engineer, or the warranty terms may become void. This service is offered as part of the sales contract for the UPS. Contact an Eaton service representative in advance (usually a two-week notice is required) to reserve a preferred startup date.

---



### CAUTION

It must be ensured that no line input source can accidentally be connected to the SPM during the SPM installation.

---



### WARNING

- Installation may only be carried out by qualified technicians and in conformity with the applicable safety standards.
  - The SPM is not suitable for IT or corner-earthed power distribution systems.
- 

### 3.1 Creating an Installation Plan

Before installing the SPM, read and understand how this manual applies to the system being installed. Use the procedures and illustrations in this section to create a logical plan for installing the SPM. This section contains the following information:

- Physical features and requirements, including dimensions
- Power wiring installation notes
- Location of conduit and wire entry landing plates
- Location of power terminals

### 3.2 Preparing the Site

Similar with the UPS, the SPM installation site should meet the environmental parameters outlined in this manual. If the UPS is to be operated at an altitude higher than 1000m (3300 ft.), contact an Eaton service representative for important information about high altitude operation. The operating environment must meet the weight, clearance, and environmental requirements specified.

### 3.2.1 Environmental and Installation Considerations

The UPS system installation, including the SPM, must meet the following guidelines:

- The system must be installed on a level floor or stiff wall which is suitable for computer or electronic equipment.
- Suitable for mounting on concrete or other non-combustible surfaces only.
- The system must be installed in a temperature and humidity controlled indoor.

Failure to follow guidelines may void your warranty.

The SPM operating environment must meet the weight requirements shown in Table 3-1 and the size requirements shown in Figure 3-1 through Figure 3-2. Dimensions are in millimetres (inches).

**Table 3-1. SPM Cabinet Weights**

Model	Weight kg (lb)		
	Shipping	Installed	Point Loading
Eaton 1+1 120kVA SPM			
Eaton 2+1 120kVA SPM	348(767)	270(595)	33.8(77.4)/wheel (total 8 wheels)
Eaton 3+1 120kVA SPM			
Eaton 1+1 200kVA SPM			
Eaton 2+1 200kVA SPM	363.5(801)	285.5(629)	35.6(78.4)/wheel (total 8 wheels)
Eaton 3+1 200kVA SPM			

No special rear clearances required for the SPM, other clearances around the SPM cabinet can follow the UPS.

**Table 3-2. SPM Cabinet Clearances**

<b>From Top of Cabinet</b>	No requirement
<b>From Front of Cabinet</b>	900 mm (36") working space
<b>From Back of Cabinet</b>	No requirement
<b>From Right Side of Cabinet</b>	No requirement
<b>From Left Side of Cabinet</b>	No requirement

The basic environmental requirements for operation of the UPS and Accessories are:

- Ambient Temperature Range: 5–40°C (41–104°F)
- Recommended Operating Range: 20–25°C (68–77°F)
- Maximum Relative Humidity: 95%, noncondensing

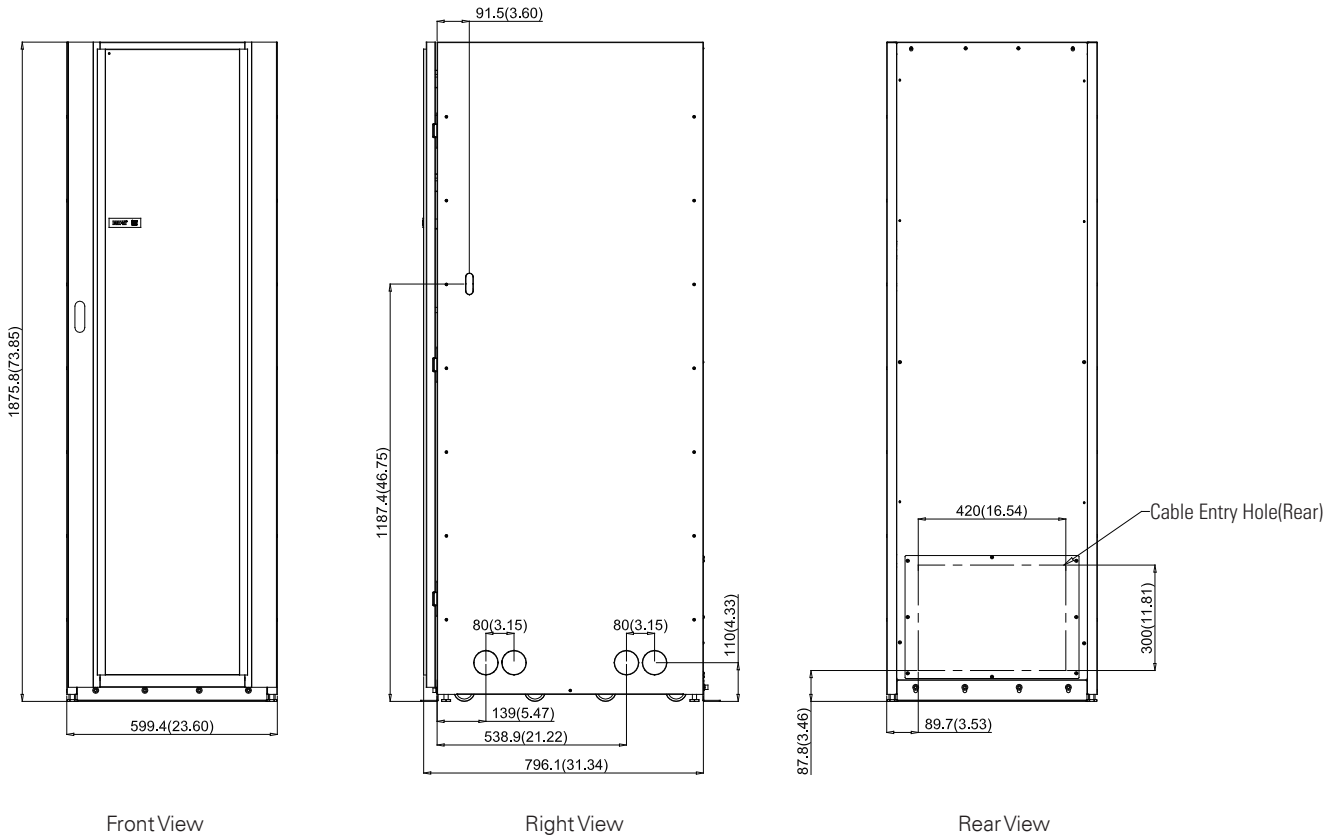

**Figure 3-1. SPM Cabinet Dimensions(Front, Right and Rear Views)**

Dimensions are in millimetres [inches]

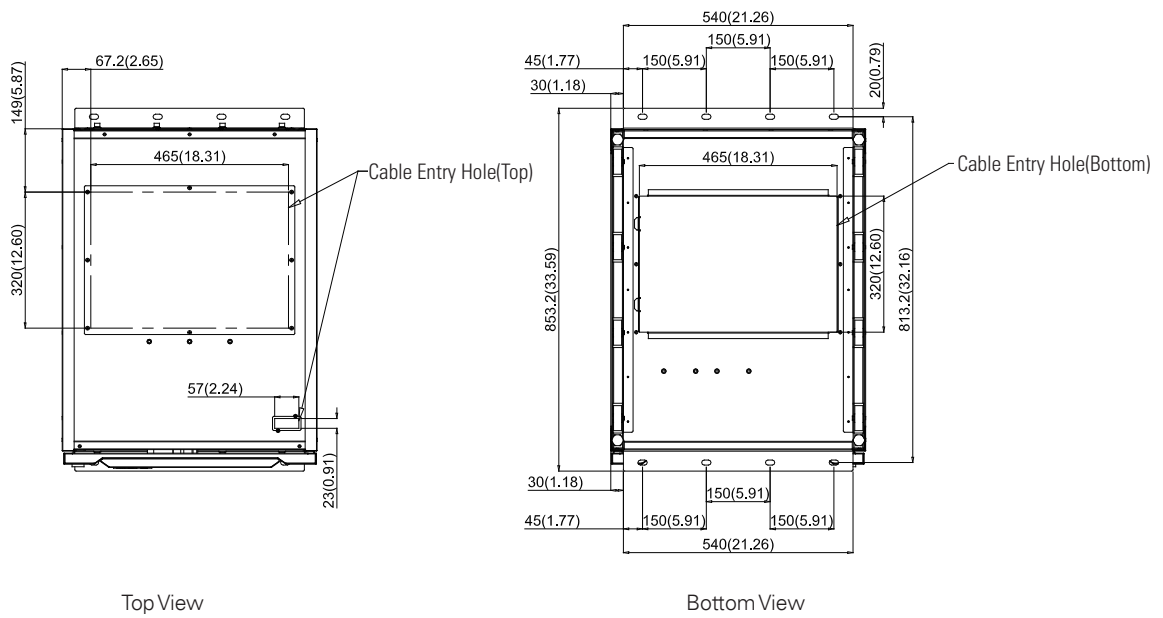

**Figure 3-2. SPM Cabinet Dimensions (Top and Bottom Views)**

Dimensions are in millimetres [inches]

### 3.2.2 SPM Wiring Preparation

Read and understand the following notes while planning and performing the installation:



#### **WARNING**

---

As a result of the connected loads high leakage current is possible. Connection to earth ground is required for safety and proper product operation. Do not check SPM operation by any action that includes removal of the earth (ground) connection with loads attached.

---

- Refer to national and local electrical codes for acceptable external wiring practices.
- Material and labor for external wiring requirements are to be provided by the customer.
- For external wiring, use 90°C copper wire. Wire sizes listed in Table 3-3 are for copper wiring only. If wire is run in an ambient temperature greater than 30°C, higher temperature wire and/or larger size wire may be necessary. Wire sizes are based on using the specified breakers.
- Refer to the appropriate Eaton 93E 80-200kVA and 93PM 50-200 kW UPS Installation and Operation manual listed in corresponding paragraph for UPS cabinet conduit and terminal specifications and locations.
- The term line-up-and-match refers to accessory cabinets that are physically located adjacent to the UPS. The term standalone refers to accessory cabinets that are located separate from the UPS.

For external power wiring requirements, including the minimum size of external wiring, see Table 3-3. Wire sizes listed are for copper wiring only.

Figure 4-5 and Figure 4-6 show the location of the SPM power cable terminals.

**Table 3-3. External Power Wiring Requirements for 93E and 93PM**

Model	Cable	Terminal	Minimum conductor size (mm <sup>2</sup> )	Number and size of Pressure termination	Tightening Torque Nm(lb in)	screw size and type
Eaton 1+1 120kVA SPM	The utility to SPM	L1	70	1-M16-Bolt-Mounting	210(23.71)	M16 Hex
		L2	70	1-M16-Bolt-Mounting	210(23.71)	M16 Hex
		L3	70	1-M16-Bolt-Mounting	210(23.71)	M16 Hex
		N	70	1-M16-Bolt-Mounting	210(23.71)	M16 Hex
	The SPM to Load	L1	70	1-M16-Bolt-Mounting	210(23.71)	M16 Hex
		L2	70	1-M16-Bolt-Mounting	210(23.71)	M16 Hex
		L3	70	1-M16-Bolt-Mounting	210(23.71)	M16 Hex
		N	70	1-M16-Bolt-Mounting	210(23.71)	M16 Hex
	The UPS to SPM MOB	L1	70	1-M16-Bolt-Mounting	210(23.71)	M16 Hex
		L2	70	1-M16-Bolt-Mounting	210(23.71)	M16 Hex
		L3	70	1-M16-Bolt-Mounting	210(23.71)	M16 Hex
		N	70	1-M16-Bolt-Mounting	210(23.71)	M16 Hex
		Ground	70	1-M10-Bolt-Mounting	45(5.1)	M10 Hex
Eaton 2+1 120kVA SPM	The utility to SPM	L1	240	1-M16-Bolt-Mounting	210(23.71)	M16 Hex
		L2	240	1-M16-Bolt-Mounting	210(23.71)	M16 Hex
		L3	240	1-M16-Bolt-Mounting	210(23.71)	M16 Hex
		N	240	1-M16-Bolt-Mounting	210(23.71)	M16 Hex
	The SPM to Load	L1	240	1-M16-Bolt-Mounting	210(23.71)	M16 Hex
		L2	240	1-M16-Bolt-Mounting	210(23.71)	M16 Hex
		L3	240	1-M16-Bolt-Mounting	210(23.71)	M16 Hex
		N	240	1-M16-Bolt-Mounting	210(23.71)	M16 Hex
	The UPS to SPM MOB	L1	70	1-M16-Bolt-Mounting	210(23.71)	M16 Hex
		L2	70	1-M16-Bolt-Mounting	210(23.71)	M16 Hex
		L3	70	1-M16-Bolt-Mounting	210(23.71)	M16 Hex
		N	70	1-M16-Bolt-Mounting	210(23.71)	M16 Hex
		Ground	240	1-M10-Bolt-Mounting	45(5.1)	M10 Hex
Eaton 3+1 120kVA SPM	The utility to SPM	L1	500	1-M16-Bolt-Mounting	210(23.71)	M16 Hex
		L2	500	1-M16-Bolt-Mounting	210(23.71)	M16 Hex
		L3	500	1-M16-Bolt-Mounting	210(23.71)	M16 Hex
		N	500	1-M16-Bolt-Mounting	210(23.71)	M16 Hex
	The SPM to Load	L1	500	1-M16-Bolt-Mounting	210(23.71)	M16 Hex
		L2	500	1-M16-Bolt-Mounting	210(23.71)	M16 Hex
		L3	500	1-M16-Bolt-Mounting	210(23.71)	M16 Hex
		N	500	1-M16-Bolt-Mounting	210(23.71)	M16 Hex
	The UPS to SPM MOB	L1	70	1-M16-Bolt-Mounting	210(23.71)	M16 Hex
		L2	70	1-M16-Bolt-Mounting	210(23.71)	M16 Hex
		L3	70	1-M16-Bolt-Mounting	210(23.71)	M16 Hex
		N	70	1-M16-Bolt-Mounting	210(23.71)	M16 Hex
		Ground	500	1-M10-Bolt-Mounting	45(5.1)	M10 Hex

Model	Cable	Terminal	Minimum conductor size (mm <sup>2</sup> )	Number and size of Pressure termination	Tightening Torque Nm(lb in)	screw size and type
Eaton 1+1 200kVA SPM	The utility to SPM	L1	150	1-M16-Bolt-Mounting	210(23.71)	M16 Hex
		L2	150	1-M16-Bolt-Mounting	210(23.71)	M16 Hex
		L3	150	1-M16-Bolt-Mounting	210(23.71)	M16 Hex
		N	150	1-M16-Bolt-Mounting	210(23.71)	M16 Hex
	The SPM to Load	L1	150	1-M16-Bolt-Mounting	210(23.71)	M16 Hex
		L2	150	1-M16-Bolt-Mounting	210(23.71)	M16 Hex
		L3	150	1-M16-Bolt-Mounting	210(23.71)	M16 Hex
		N	150	1-M16-Bolt-Mounting	210(23.71)	M16 Hex
	The UPS to SPM MOB	L1	150	1-M16-Bolt-Mounting	210(23.71)	M16 Hex
		L2	150	1-M16-Bolt-Mounting	210(23.71)	M16 Hex
		L3	150	1-M16-Bolt-Mounting	210(23.71)	M16 Hex
		N	150	1-M16-Bolt-Mounting	210(23.71)	M16 Hex
		Ground	150	1-M10-Bolt-Mounting	45(5.1)	M10 Hex
Eaton 2+1 200kVA SPM	The utility to SPM	L1	630	1-M16-Bolt-Mounting	210(23.71)	M16 Hex
		L2	630	1-M16-Bolt-Mounting	210(23.71)	M16 Hex
		L3	630	1-M16-Bolt-Mounting	210(23.71)	M16 Hex
		N	630	1-M16-Bolt-Mounting	210(23.71)	M16 Hex
	The SPM to Load	L1	630	1-M16-Bolt-Mounting	210(23.71)	M16 Hex
		L2	630	1-M16-Bolt-Mounting	210(23.71)	M16 Hex
		L3	630	1-M16-Bolt-Mounting	210(23.71)	M16 Hex
		N	630	1-M16-Bolt-Mounting	210(23.71)	M16 Hex
	The UPS to SPM MOB	L1	150	1-M16-Bolt-Mounting	210(23.71)	M16 Hex
		L2	150	1-M16-Bolt-Mounting	210(23.71)	M16 Hex
		L3	150	1-M16-Bolt-Mounting	210(23.71)	M16 Hex
		N	150	1-M16-Bolt-Mounting	210(23.71)	M16 Hex
		Ground	630	1-M10-Bolt-Mounting	45(5.1)	M10 Hex
Eaton 3+1 200kVA SPM	The utility to SPM	L1	2*400	2-M16-Bolt-Mounting	210(23.71)	M16 Hex
		L2	2*400	2-M16-Bolt-Mounting	210(23.71)	M16 Hex
		L3	2*400	2-M16-Bolt-Mounting	210(23.71)	M16 Hex
		N	2*400	2-M16-Bolt-Mounting	210(23.71)	M16 Hex
	The SPM to Load	L1	2*400	2-M16-Bolt-Mounting	210(23.71)	M16 Hex
		L2	2*400	2-M16-Bolt-Mounting	210(23.71)	M16 Hex
		L3	2*400	2-M16-Bolt-Mounting	210(23.71)	M16 Hex
		N	2*400	2-M16-Bolt-Mounting	210(23.71)	M16 Hex
	The UPS to SPM MOB	L1	150	1-M16-Bolt-Mounting	210(23.71)	M16 Hex
		L2	150	1-M16-Bolt-Mounting	210(23.71)	M16 Hex
		L3	150	1-M16-Bolt-Mounting	210(23.71)	M16 Hex
		N	150	1-M16-Bolt-Mounting	210(23.71)	M16 Hex
		Ground	2*400	1-M10-Bolt-Mounting	45(5.1)	M10 Hex



### 3.3. Inspecting and Unpacking the SPM

The cabinet is shipped bolted to a wooden pallet and covered with outer protective packaging material (see Figure 3-3).



**NOTE**

Startup and operational checks must be performed by an authorized Eaton Customer Service Engineer, or the warranty terms specified become void. This service is offered as part of the sales contract for the UPS. Contact an Eaton service representative in advance (usually a two-week notice is required) to reserve a preferred startup date.



**WARNING**

The Accessory cabinet is heavy (see Table 3-1). If unpacking and unloading instructions are not closely followed, the cabinet may tip and cause serious injury.

1. Carefully inspect the outer packaging for evidence of damage during transit.



**CAUTION**

Do not install a damaged cabinet. Report any damages to the carrier and contact an Eaton service representative immediately.



**NOTE**

For the following step, verify that the forklift or pallet jack is rated to handle the weight of the cabinets (see Table 3-1 for cabinet weight).

2. Use a forklift or pallet jack to move the packaged cabinet to the installation site, or as close as possible, before unpacking. If possible, move the cabinets using the pallet. Insert the forklift or pallet jack forks between the supports on the bottom of the pallet .



**CAUTION**

- Do not tilt the SPM cabinets more than 10° from vertical or the cabinets may tip over.

3. Remove the protective wood/carton container from the cabinet:



**NOTE**

For the following steps, use pincer type pliers or a large flat blade screw driver to straighten the securing tabs.

- a. Straighten the tabs securing the top panel of the wooden container to the side panels of the container.
  - b. Remove the top panel and retain for later use as a ramp in unloading the cabinet from the pallet.
  - c. Straighten the tabs securing the side panels of the container to the front and back panels of the container.
  - d. Remove the side panels.
  - e. Straighten the tabs securing the front and back panels of the container to the bottom of the container.
  - f. Remove the front and back panels.
4. Remove the inner protective packaging. Retain the parts kit box, ramp brackets, and ramp extension packed at the top of the cabinet.

5. Recycle the remainder of the outer shipping container and the inner protective packaging in a responsible manner.
6. Inspect the contents for any evidence of physical damage, and compare each item with the Bill of Lading. If damage has occurred or shortages are evident, contact an Eaton service representative immediately to determine the extent of the damage and its impact on further installation.



**NOTE**

While waiting for installation, protect the unpacked cabinet from moisture, dust, and other harmful contaminants. Failure to store and protect the SPM properly may void your warranty.

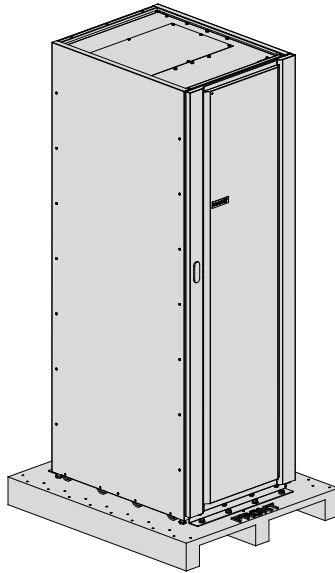

**Figure 3-3. SPM Cabinet as Shipped on Pallet (wood container removed)**

### 3.4 Breaker Location

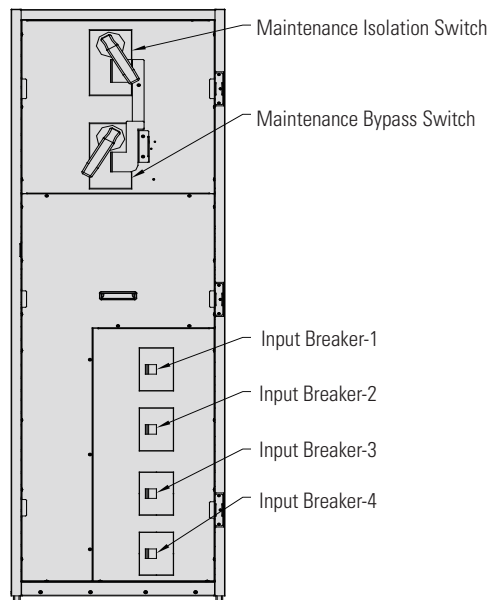

**Figure 3-4. Breaker Location**

## Chapter 4 Installation

### 4.1 Preliminary Installation Information

---

 **WARNING**

---

Wires enter/out can from the bottom, top and rear holes of cabinet.

---

Refer to the following while installing the SPM:

- To review the SPM manual, Chapter 3 of this manual for cabinet dimensions, equipment weight, wiring and installation notes.
- Do not tilt the cabinets more than  $\pm 10^\circ$  during installation.
- Suitable for mounting on concrete or other non-combustible surfaces only.

### 4.2 Unloading the SPM Cabinet from the Pallet

The SPM is bolted to a wooden pallet supported by wood skids.

---

 **WARNING**

---

The SPM cabinet is heavy (see Table 3-1). If unpacking and unloading instructions are not closely followed, the cabinet may tip and cause serious injury.

---

---

 **CAUTION**

---

- Do not tilt cabinet more than  $10^\circ$  from vertical.
  - Lift the cabinets only with a forklift or damage may occur.
- 



**NOTE**

The SPM uses inline wheels, not swivel casters. When moving the SPM, move the cabinet in straight lines as much as possible, minimizing turns.

For the following steps, verify that the forklift or pallet jack is rated to handle the weight of the cabinet (see Table 3-1 for cabinet weight).

---

1. If not already accomplished, use a forklift or pallet jack to move the SPM cabinet to the installation area, or as close as possible, before unloading from the pallet. Insert the forklift or pallet jack forks between the supports on the bottom of the pallet .
2. Remove four bolts securing the front shipping bracket to the cabinet and four bolts securing the bracket to the pallet (see Figure 4-1). Remove the front shipping bracket. If installing the cabinet permanently, retain the shipping bracket and securing hardware for later use.
3. Attach the ramp to the front of the pallet (see Figure 4-2):
  - a. Locate the ramp (top panel from wood container), ramp extension, and ramp brackets with M10 bolts.
  - b. Place the ramp against the front of the pallet.
  - c. Attach the ramp extension to the front of the ramp by inserting the tabs on the extension into the slots at the bottom of the ramp.
4. If the leveling feet are not fully retracted, turn the leveling feet until they are retracted.
5. Remove four bolts securing the rear shipping bracket to the cabinet and four bolts securing the bracket to the pallet (see Figure 4-3). Remove the rear shipping bracket. If installing the cabinet permanently, retain the shipping bracket and securing hardware for later use.

6. Slowly roll the cabinet toward the front of the pallet. Continue rolling the cabinet down the ramp until the cabinet is clear of the ramp (see Figure 4-4).
7. Roll the cabinet to the final installation location.
8. If installing the cabinet permanently, retain the shipping brackets and hardware; otherwise, recycle the pallet, ramp, and shipping brackets in a responsible manner.
9. Secure the UPS cabinet in position by lowering the leveling feet until the cabinet is not resting on the casters and the cabinet is level.
10. If permanently mounting the system, proceed to Step 11;
11. Using the retained hardware, reinstall the shipping brackets removed in Step 2 and Step 5 to the front and rear of the UPS cabinet with the angle facing outward (see Figure 4-1 and Figure 4-3).
12. Secure the cabinet to the floor with customer-supplied hardware.

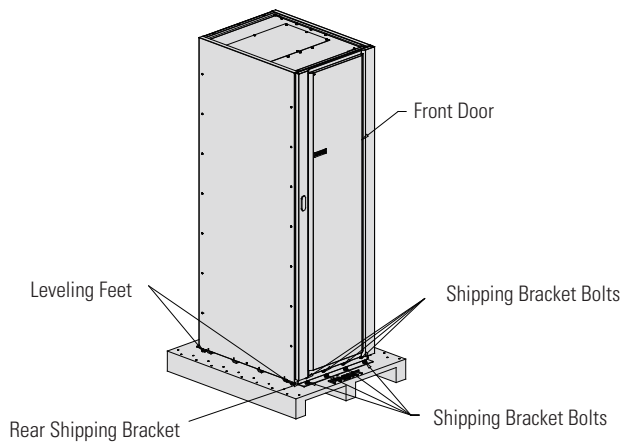

**Figure 4-1. Removing the Front Shipping Bracket**

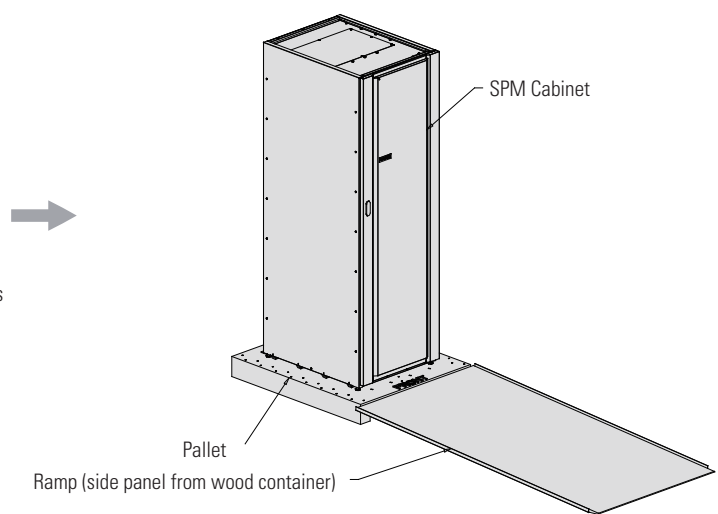

**Figure 4-2. Attaching the Ramp to the Pallet**

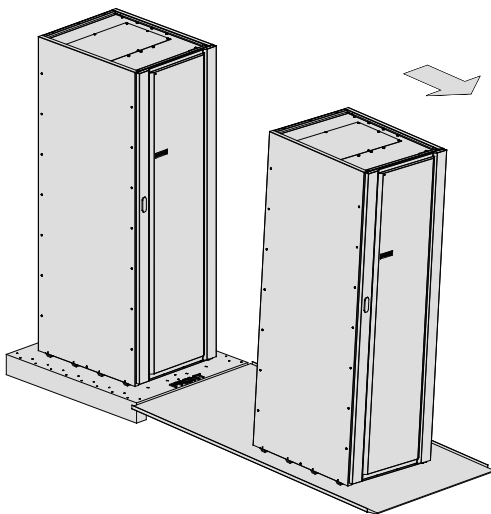

**Figure 4-3. Removing the Rear Shipping Bracket**

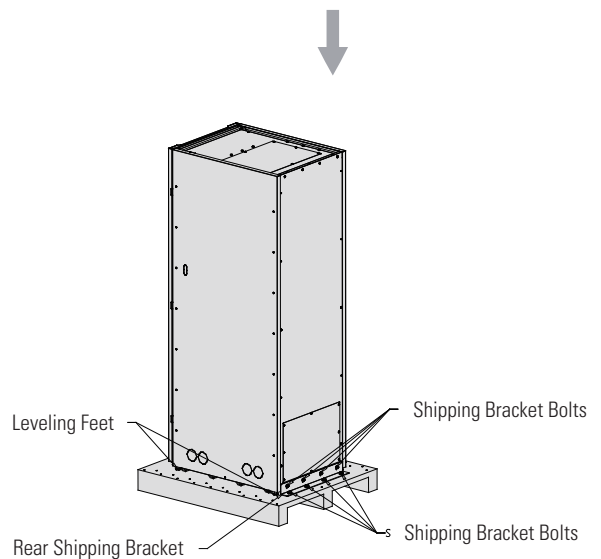

**Figure 4-4. Rolling the Cabinet Down the Ramp**

### 4.3 External Power Cables Connecting

**NOTE**

Wires enter/out from the bottom conduit landing plate or knock-out holes on 2 side plates.

---

**WARNING**

- TURN OFF UPS AND DISCONNECT UPS FROM POWER SUPPLY BEFORE SPM INSTALLATION.
  - HIGHTOUCH CURRENT. EARTH CONNECTION MUST BEFORE CONNECTING SUPPLY. As a result of the connected loads high leakage current is possible. Connection of the earth (ground) is required for proper product operation. Do not check UPS operation by removal of the Earth (ground) connection.
- 

To install wires:

1. If installing wiring using conduit, please punch or drill hole on the bottom and top cover plates.
2. Install conduit between the UPS cabinet and SPM if needed.
3. Ground the SPM according to local and/or national electrical wiring codes by routing and connecting the ground wire to the input ground lug. See Figure 4-5 for SPM terminal locations.
4. Route and connect the power cables(L1,L2,L3,N) from the utility source to the SPM phase and terminal blocks. See Figure 4-5 for wiring access information and terminal locations. See paragraph 3.2.2,Table 3-3 for wiring and termination requirements.

The utility source must be the same as the UPS bypass input.

---

**WARNING**

Verify phases of connections. Risk of personal injury and damage to equipment from arc flash if connections are reversed.

---

5. Route and Connect the power cables(L1,L2,L3,N ) from the Load to the SPM phase and terminal blocks. See Figure 4-5 for wiring access information and terminal locations. See paragraph 3.2.2,Table 3-3 for wiring and termination requirements.
6. 5 Route and Connect the power cables(L1,L2,L3,N ) from the UPS to the SPM phase terminal blocks. See Figure 4-5 for wiring access information and terminal locations. See paragraph 3.2.2,Table 3-3 for wiring and termination requirements.

### 4.4 External Signaling Cables Connecting

**NOTE**

To avoid the interface between the power cables and signal wires, please route the cables separate.

---

To install the signal wires:

Refer figure 4-6 to install the signal wires. The wire code is minimum 22AWG.

1. Please refer to the appropriate Eaton 93E80-200kVA and 93PM 50-200kW UPS installation and operation manual listed in corresponding paragraph for pull chain and building alarm connections.
2. To located the appropriate terminals and review the wiring and terminal requirement see Figure 4-6.

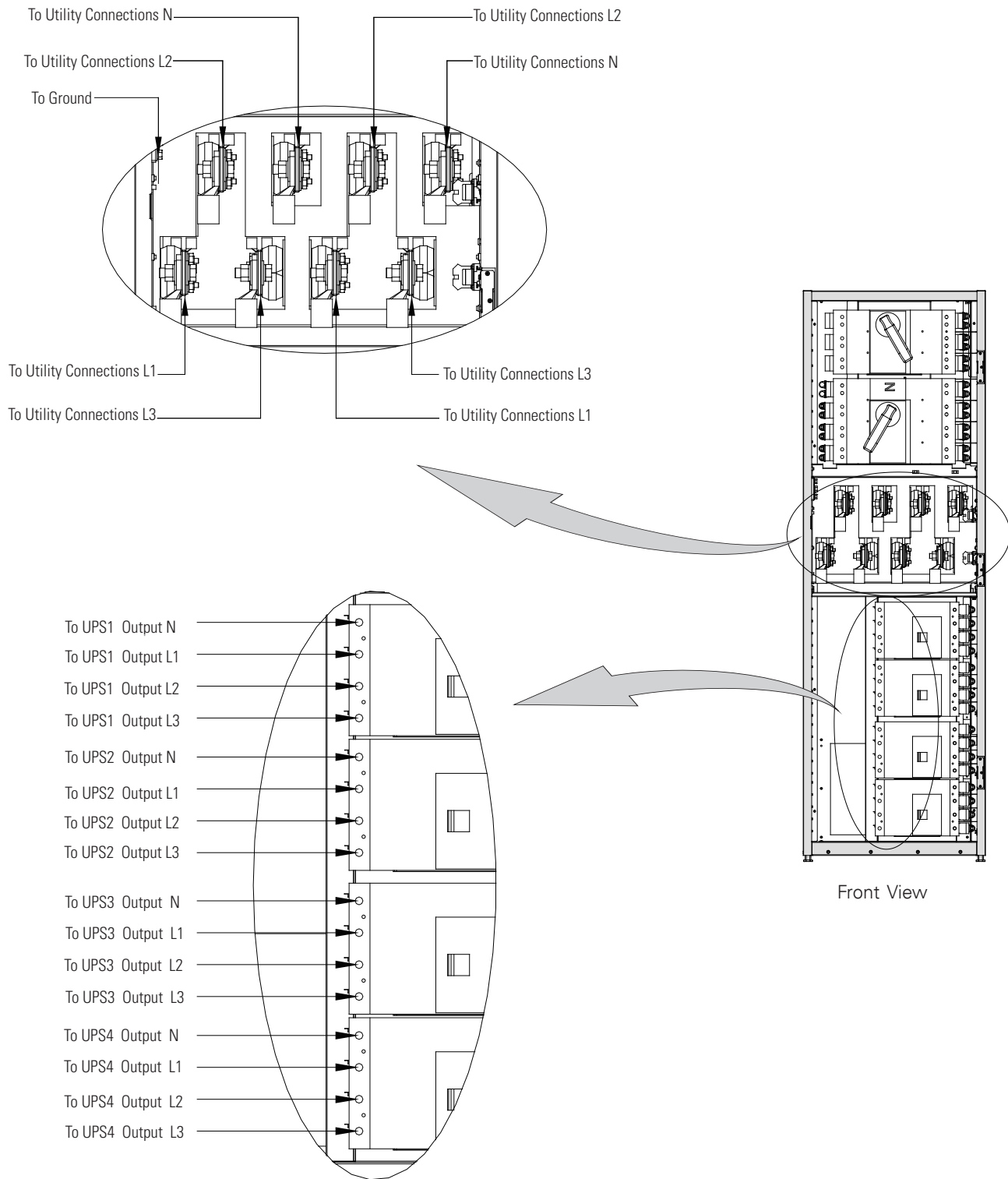

**Figure 4-5. Power Terminal Locations**

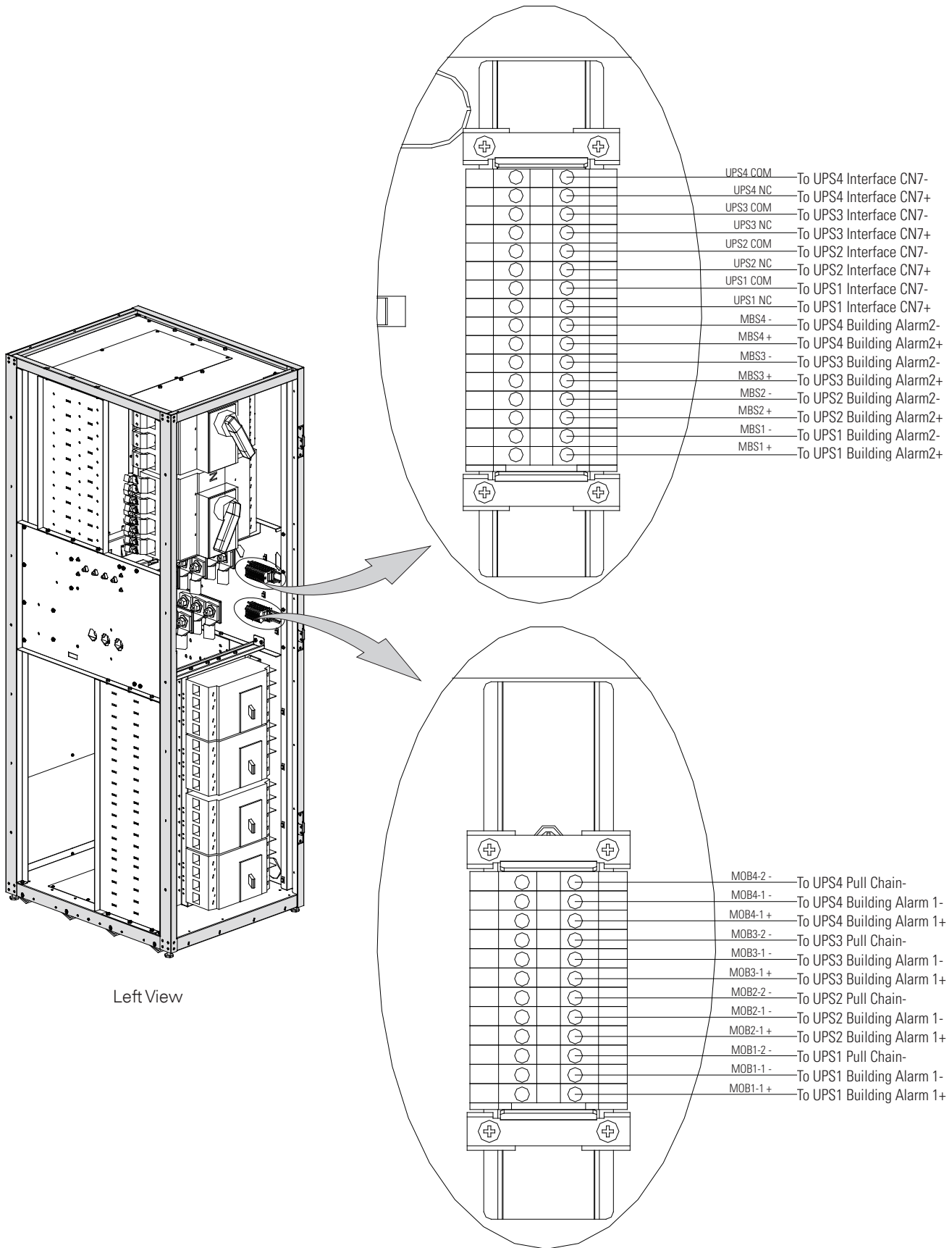

**Figure 4-6. Power and Signal Terminal Locations**

## 4.5 Initial Startup

Startup and operational checks must be performed by an authorized Eaton Customer Service Engineer, or the warranty terms specified become void. This service is offered as part of the sales contract for the SPM. Contact an Eaton service representative in advance (usually a two-week notice is required) to reserve a preferred startup date.

## 4.6 Completing the Installation Checklist

The final step in installing the SPM is completing the following Installation Checklist. This checklist ensures that you have completely installed all hardware, cables, and other equipment. Complete all items listed on the checklist to ensure a smooth installation. Make a copy of the Installation Checklist before filling it out, and retain the original.

After the installation is complete, an Eaton Customer Service Engineer must verify the operation of the UPS system and commission it to support the critical load. The service representative cannot perform any installation tasks other than verifying software and operating setup parameters. Service personnel may request a copy of the completed Installation Checklist to verify all applicable equipment installations have been completed.

**NOTE**

The Installation Checklist **MUST** be completed prior to starting the UPS system for the first time.

---

Installation Checklist:

- All packing materials and restraints have been removed from each cabinet.
- The SPM is installed on a level floor suitable for computer or electronic equipment.
- The SPM is placed in its installed location
- All conduits and cables are properly routed from the SPM to the UPS and load.
- All power cables are properly sized and terminated.
- A ground conductor is properly installed.
- All terminal cover plates (if have) are installed.
- Air conditioning equipment is installed and operating correctly.
- The area around the UPS system is clean and dust-free.
- Adequate workspace exists around the SPM and other cabinets.
- Adequate lighting is provided around all SPM and UPS equipment.
- Startup and operational checks are performed by an authorized Eaton Customer Service Engineer.





# Chapter 5 Onelines and Schematics

## 5.1 Schematics

Figure 5-1 show the SPM schematics.

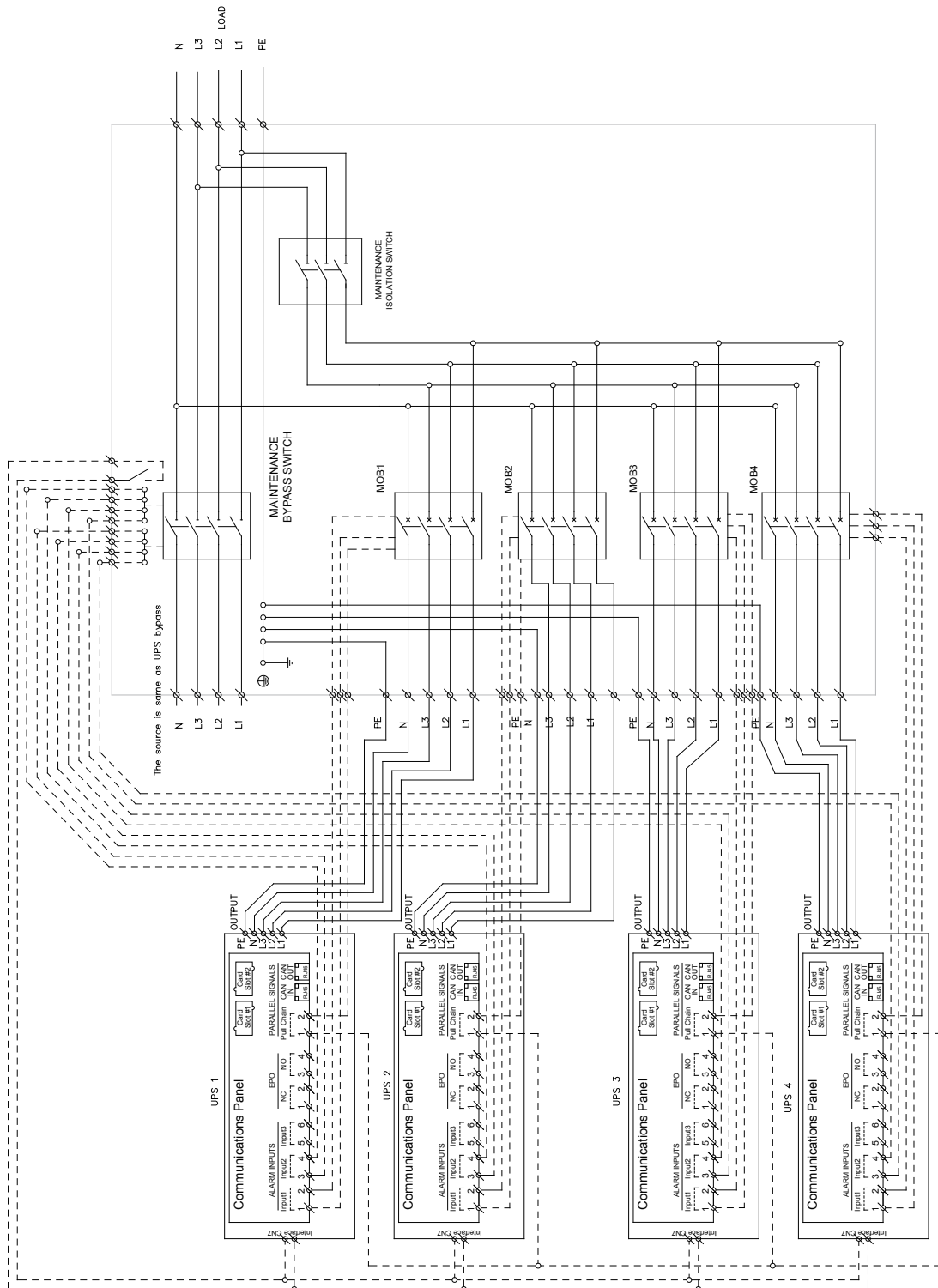

Figure 5-1. SPM Schematics

## Chapter 6 Maintenance

The components inside the SPM are secured to a sturdy metal frame. All repairable parts and assemblies are located for easy removal, with very little disassembly. This design allows authorized service personnel to perform routine maintenance and servicing quickly.

You must schedule periodic performance checks of the UPS system to keep it running properly. Regular routine checks of operation and system parameters enable your system to function efficiently for many trouble-free years.

### 6.1 Important Safety Instructions

Remember that your UPS system is designed to supply power EVEN WHEN DISCONNECTED FROM THE UTILITY POWER.

---

 **WARNING**

---

- No user serviceable components.
  - Servicing and maintenance should be performed by qualified service personnel only.
  - LETHAL VOLTAGE PRESENT. This unit should not be operated with the cabinet doors open or protective panels removed. Do not make any assumptions about the electrical state of any cabinet in the UPS system.
- 

### 6.2 Performing Preventive Maintenance

The UPS system requires very little preventive maintenance. However, the system should be inspected periodically to verify that the units are operating normally. Record maintenance results and any corrective actions in a suitable log.

#### 6.2.1 DAILY Maintenance

Perform the following steps daily:

1. Check the area surrounding the UPS system. Ensure the area is not cluttered, allowing free access to the unit.
2. Ensure the operating environment is within the parameters specified in paragraph 3.2.1 and Chapter 7, "Product Specifications."

#### 6.2.2 PERIODIC Maintenance

Periodic inspections of the SPM should be made to determine if components, wiring, and connections exhibit evidence of overheating. Particular attention should be given to the compression lug connections. Maintenance procedures should specify that the compression lug connections be re-torqued to values listed in this manual.

#### 6.2.3 ANNUAL Maintenance

Annual preventive maintenance should be performed only by authorized service personnel familiar with maintenance and servicing of the UPS system. Contact an Eaton service representative for more information about service offerings.

#### 6.2.4 BATTERY Maintenance

Contact an Eaton service representative for battery maintenance. Battery replacement and maintenance should be performed only by authorized service personnel.

### 6.3 Maintenance Training

A basic training course, available from Eaton Corporation, gives you a competent working knowledge of the UPS system operation and teaches you how to perform first level corrective maintenance. For more information about training and other services, contact the Help Desk .see paragraph 1.7.

## Chapter 7 Product Specifications

This section provides the following specifications:

- Model Numbers
- Environmental and safety specifications

### 7.1 Specifications

The following sections detail the SPM specifications and the environmental and safety specifications for the SPM. Environmental and Safety Specifications.

#### 7.1.1 Electrical specifications

Basic Unit Rating	Units	Rating 50/60Hz	
	kVA	120kVA x 3	200kVA x 3
Input and output voltage	Volts	415	415
Max. current of MBS	Amps	705	1173
Max. current of MIS	Amps	654	1086
Max. current of MOB	Amps	218	362

#### 7.1.2 Environmental specifications

<b>Operating Temperature</b> ①	5°C – 40°C
<b>Storage Temperature</b> ①	-25°C to 55°C
<b>Transit Temperature</b> ①	-25°C to 60°C
<b>Humidity</b>	5 % to 95 % maximum noncondensing
<b>Enclosure Class per IEC 60529</b>	IP20, Optional 21
<b>RoHS/WEEE</b>	Required
<b>Operating Altitude</b> ②	Maximum 1000m at 30°C without derating

① The recommended operational, storage and transit temperature with CSB and C&D batteries is generally max. 25°C. Please refer to the battery manufacturer's recommendations for accurate temperatures.

② Altitude-thermal de-rating as per EN62040-3:2011.







